

JVC



COMPACT DISC RECORDER

ENREGISTREUR DE DISQUES LASER

XL-R910SL

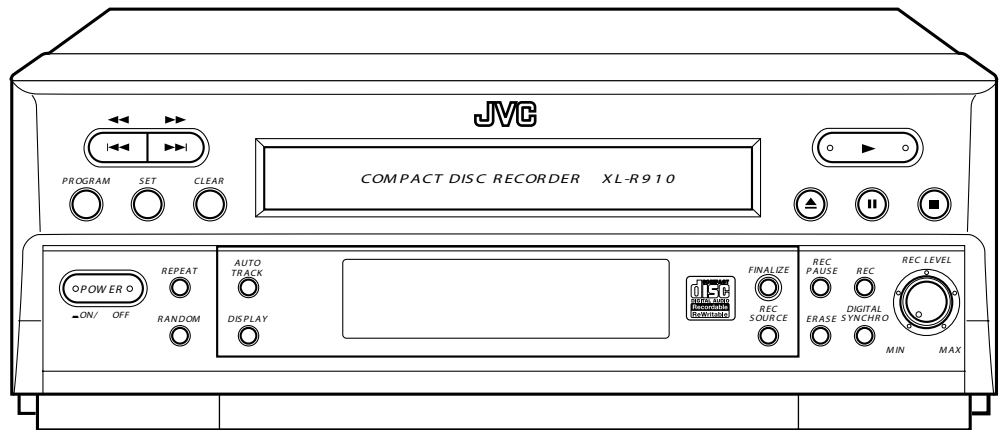
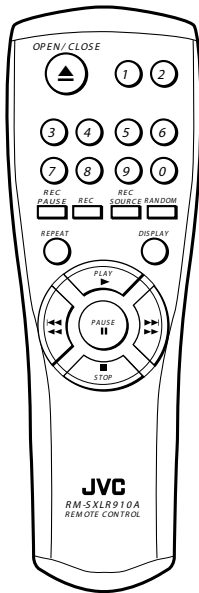

INSTRUCTIONS

MANUAL D'INSTRUCTIONS

For Customer Use:

Enter below the Model No. and Serial No. which are located either on the rear, bottom or side of the cabinet. Retain this information for future reference.

Model No. _____

Serial No. _____

Warnings, Cautions and Others



The lightning flash with arrowhead symbol, within an equilateral triangle is intended to alert the user to the presence of uninsulated "dangerous voltage" within the product's enclosure that may be of sufficient magnitude to constitute a risk of electric shock to persons.



The exclamation point within an equilateral triangle is intended to alert the user to the presence of important operating and maintenance (servicing) instructions in the literature accompanying the appliance.

WARNING: TO REDUCE THE RISK OF FIRE OR ELECTRIC SHOCK, DO NOT EXPOSE THIS APPLIANCE TO RAIN OR MOISTURE.

CAUTION

To reduce the risk of electrical shocks, fire, etc.:

1. Do not remove screws, covers or cabinet.
2. Do not expose this appliance to rain or moisture.

ATTENTION

Afin d'éviter tout risque d'électrocution, d'incendie, etc.:

1. Ne pas enlever les vis ni les panneaux et ne pas ouvrir le coffret de l'appareil.
2. Ne pas exposer l'appareil à la pluie ni à l'humidité.

■ Caution — POWER switch

This apparatus is provided with a POWER switch to be able to minimize power consumption for safe use.

Therefore,

1. When doing initial setting, complete all the connections required, connect the mains plug into the wall outlet, and set the POWER switch to ON.
2. When not in use, set the POWER switch to OFF.
3. Disconnect the mains plug to shut the power off completely. The POWER switch in any position do not disconnect the mains line.

■ Précaution — interrupteur POWER

Cet appareil est doté d'un interrupteur POWER qui permet de réduire la consommation d'énergie à des fins de sécurité. En conséquence,

1. Lors des réglages initiaux, effectuer tous les raccordements, brancher la fiche secteur dans la prise secteur, puis mettre l'interrupteur POWER sur ON.
2. Lorsqu'on ne sert pas de l'appareil, mettre l'interrupteur POWER sur OFF.
3. Débrancher l'appareil de la prise secteur pour couper complètement l'alimentation. L'interrupteur POWER ne coupe pas l'appareil du secteur, quelle que soit la position sur laquelle il est réglé.

For Canada/pour le Canada

CAUTION: TO PREVENT ELECTRIC SHOCK, MATCH WIDE BLADE OF PLUG TO WIDE SLOT, FULLY INSERT
ATTENTION: POUR EVITER LES CHOCS ELECTRIQUES, INTRODUIRE LA LAME LA PLUS LARGE DE LA FICHE DANS LA BORNE CORRESPONDANTE DE LA PRISE ET POUSSER JUSQU'AU FOND

For U.S.A.

This equipment has been tested and found to comply with the limits for a Class B digital device, pursuant to part 15 of the FCC Rules. These limits are designed to provide reasonable protection against harmful interference in a residential installation.

This equipment generates, uses and can radiate radio frequency energy and, if not installed and used in accordance with the instructions, may cause harmful interference to radio communications. However, there is no guarantee that interference will not occur in a particular installation. If this equipment does cause harmful interference to radio or television reception, which can be determined by turning the equipment off and on, the user is encouraged to try to correct the interference by one or more of the following measures:

Reorient or relocate the receiving antenna.

Increase the separation between the equipment and receiver.

Connect the equipment into an outlet on a circuit different from that to which the receiver is connected.

Consult the dealer or an experienced radio/TV technician for help.

For Canada/pour Le Canada

THIS DIGITAL APPARATUS DOES NOT EXCEED THE CLASS B LIMITS FOR RADIO NOISE EMISSIONS FROM DIGITAL APPARATUS AS SET OUT IN THE INTERFERENCE-CAUSING EQUIPMENT STANDARD ENTITLED "DIGITAL APPARATUS," ICES-003 OF THE DEPARTMENT OF COMMUNICATIONS.

CET APPAREIL NUMERIQUE RESPECTE LES LIMITES DE BRUITS RADIOELECTRIQUES APPLICABLES AUX APPAREILS NUMERIQUES DE CLASSE B PRESCRITES DANS LA NORME SUR LE MATERIEL BROUILLEUR; "APPAREILS NUMERIQUES", NMB-003 EDICTEE PAR LE MINISTRE DES COMMUNICATIONS.

IMPORTANT FOR LASER PRODUCTS

Precautions:

1. CLASS 1 LASER PRODUCT
2. **DANGER:** Invisible laser radiation when open and interlock failed or defeated. Avoid direct exposure to beam.
3. **CAUTION:** Do not open the top cover. There are no user-serviceable parts inside. Leave all servicing to qualified service personnel.

IMPORTANT POUR PRODUITS LASER

Precautions

1. PRODUIT LASER CLASSE 1
2. **DANGER:** Radiation laser invisible quand l'appareil est ouvert ou que le verrouillage est en panne ou désactivé. Éviter une exposition directe au rayon.
3. **ATTENTION:** Ne pas ouvrir le volet supérieur. Il n'y a pas de pièce réparable par l'utilisateur à l'intérieur. Confier le service après-vente à un personnel qualifié.

Table of Contents

Before Operating the Unit	2
Before Installation	2
About Discs and Their Logos	2
Location of the Buttons and Controls	3
Getting Started	5
Checking the Supplied Accessories	5
Putting Batteries in the Remote Control	5
Connecting the Unit	5
Playing Back a Disc	7
1 Turn On the Power	7
2 Load a Disc	7
3 Start Playback	7
Basic Playback Operations	8
Selecting Playback Modes	9
Programming the Playing Order of the Tracks	
— Program Play	9
Playing at Random — Random Play	10
Recording on a CD-R/CD-RW	11
• Before You Start Recording	11
• Using Automatic Tracking while Recording	11
• Adjusting the Recording Level through the Analog	
Input Jacks	11
1 Load a Recordable Disc and Prepare the Playback Source ..	12
2 Select the Recording Source (Input)	12
3 Start Recording	12
Other Recording Functions	13
Synchronized Digital Recording	13
Finalizing a Disc — CD-R/CD-RW	14
Unfinalizing a Disc — CD-RW	14
Erasing the Tracks on a CD-RW	14
Additional Information	15
Glossary	15
Maintenance	16
Handling Discs	16
Troubleshooting	17
Specifications	18



This mark indicates that the remote control **CAN ONLY** be used for the operation explained.



This mark indicates that only the remote control **CANNOT** be used for the operation explained.

Before Operating the Unit

Thank you for purchasing this JVC product. Please read these instructions thoroughly and carefully before starting operation to ensure that you will derive the optimum performance and a long service life from your unit.

Before Installation

General Precautions

- DO NOT insert any metal object into the unit.
- DO NOT disassemble the unit or remove screws, covers, or cabinet.
- DO NOT modify the power cord in any way.
- DO NOT bend the cord at a sharp angle, and do not pull or twist it.
- DO NOT expose the unit to rain or moisture.

Locations

- Install the unit in a location that is level and protected from moisture.
- The temperature around the unit must be between 41°F and 95°F (5°C and 35°C).
- Make sure there is good ventilation around the unit. Poor ventilation could cause overheating and damage the unit.
- Avoid placing the unit on or adjacent to an amplifier. This is to prevent the humming caused by the unit's proximity to some types of amplifiers. Move the unit where it will not be affected by the amplifier.

Handling the unit

- DO NOT touch the power cord with wet hands.
- DO NOT pull on the power cord to unplug the cord. When unplugging the cord, always grasp the plug so as not to damage the cord.
- If the power cord is damaged, consult your dealer.

About Discs and Their Logos

Recording

This unit has been designed to record on the discs bearing the following logos:



In addition to the logos shown above, the phrases shown below or their equivalent should also be indicated somewhere on the package or accompanying documentation.

- For Customer Use
- For Music Use

The following discs cannot be used for recording:

- Discs bearing logos other than the above.
- Discs intended for professional use.
- Discs intended for recording computer data.

Playback

This unit has been also designed to play back on the discs bearing the following logos:



In addition to the above discs, this unit can play back audio data recorded on CD-G (CD Graphics), CD-EXTRA, and CD-Text discs.

Note:

This unit can playback a CD-R or CD-RW recorded on a personal computer only if it has been recorded in the CD audio format.

Location of the Buttons and Controls

Be familiar with the buttons and controls on your unit.

Front Panel

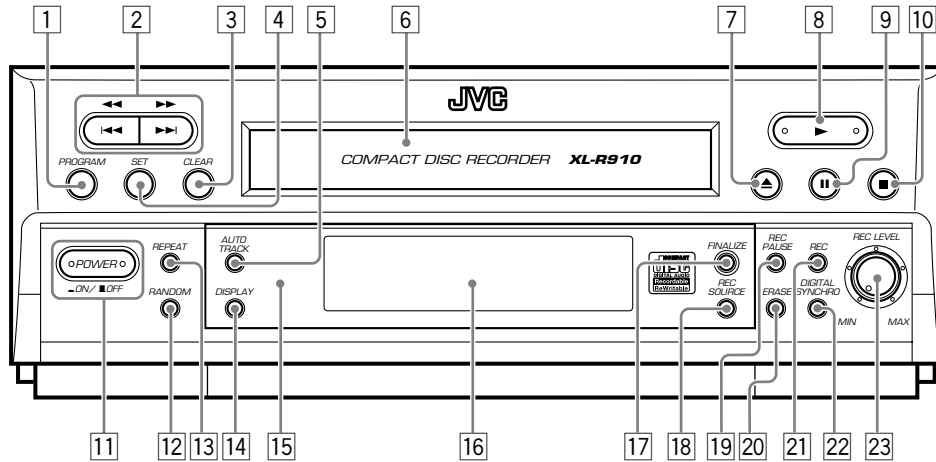

Remote Control

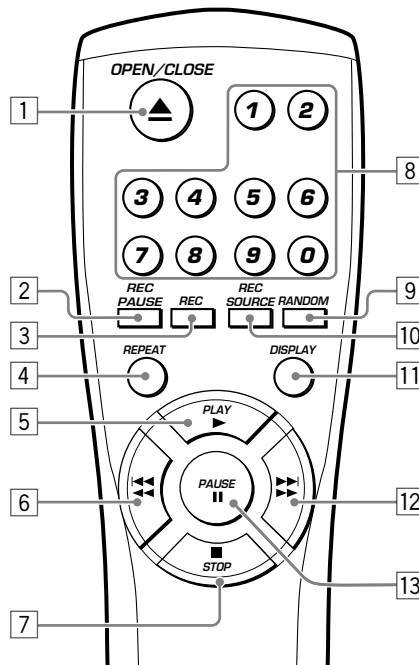

Display Window

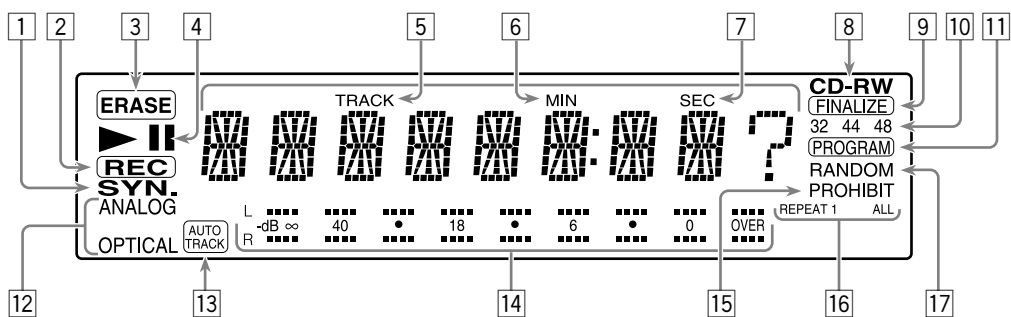

See pages in the parentheses for details.

Front Panel

- 1 PROGRAM button (9)
- 2 ◀◀/◀◀ (Reverse Skip/Reverse Search) buttons (8 – 10)
▶▶/▶▶ (Forward Skip/Forward Search) buttons (8 – 10)
- 3 CLEAR button (9, 10, 14)
- 4 SET button (13, 14)
- 5 AUTO TRACK button (11)
- 6 Disc tray
- 7 ▲ (Open/Close) button (7, 12)
- 8 ▶ (Play) button (7, 9)
- 9 || (Pause) button (8)
- 10 ■ (Stop) button (7, 9, 10, 12, 13)
- 11 POWER button (7, 12)
- 12 RANDOM button (10)
- 13 REPEAT button (8)
- 14 DISPLAY button (8)
- 15 Remote sensor
- 16 Display window
- 17 FINALIZE button (14)
- 18 REC SOURCE button (12, 13)
- 19 REC PAUSE button (12)
- 20 ERASE button (14)
- 21 REC button (12)
- 22 DIGITAL SYNCHRO button (13)
- 23 REC LEVEL control (11)

Remote Control

- 1 OPEN/CLOSE ▲ button (7, 12)
- 2 REC PAUSE button (12)
- 3 REC button (12)
- 4 REPEAT button (8)
- 5 PLAY ▶ button (7, 9)
- 6 ◀◀/◀◀ (Reverse Skip/Reverse Search) buttons (8 – 10)
- 7 STOP ■ button (7, 9, 10, 12, 13)
- 8 Number buttons (8)
- 9 RANDOM button (10)
- 10 REC SOURCE button (12, 13)
- 11 DISPLAY button (8)
- 12 ▶▶/▶▶ (Forward Skip/Forward Search) buttons (8 – 10)
- 13 PAUSE || button (8)

Display Window

- 1 SYN. (Synchronization) indicator (13)
 - Lights up when Digital Synchronized Recording mode is activated.
- 2 REC (Recording) indicator (12, 13)
 - Lights up while recording. (Also lights up while recording pause – with the || indicator this time.)
- 3 ERASE indicator (14)
- 4 ▶ (Play)/|| (Pause) indicators (7, 8)
 - ▶ : Lights up during play.
 - || : Lights up during pause.
- 5 TRACK indicator
 - Lights up when the track number is shown below this indicator.
- 6 MIN (Minute) indicator
 - Lights up when the minutes are shown below this indicator.
- 7 SEC (Second) indicator
 - Lights up when the seconds are shown below this indicator.
- 8 Disc indicator
 - CD, CD-R, CD-RW
 - Lights up to indicate the type of the disc loaded.
- 9 FINALIZE indicator (14)
 - Lights up when a finalized disc is loaded.
- 10 Sampling frequency indicators
 - 32, 44, 48
 - Lights up to indicate the sampling frequency of the incoming signal.
- 11 PROGRAM indicator (9)
 - Lights up when the unit is in program play mode.
- 12 Recording source (input) indicators (12, 13)
 - ANALOG, OPTICAL
 - Lights up to indicate the recording source (input).
- 13 AUTO TRACK indicator (11)
 - Lights up when Automatic Tracking is activated.
- 14 Level indicator
 - Illuminates to indicate the signal level.
- 15 PROHIBIT indicator
 - Lights up when recording from the loaded disc is prohibited.
- 16 Repeat mode indicator (8)
 - REPEAT 1, REPEAT ALL
 - Lights up to indicate repeat play mode.
- 17 RANDOM indicator (10)
 - Lights up while the unit is in random play mode.

Getting Started

Checking the Supplied Accessories

Check to be sure you have all of the following supplied accessories. The number in the parentheses indicates the quantity of the pieces supplied.

- Remote Control (1)
- Batteries (2)
- Audio cord (2)
- Optical digital cord (1)

If anything is missing, contact your dealer immediately.

Putting Batteries in the Remote Control

Before using the remote control, put two supplied batteries first.

- When using the remote control, aim the remote control directly at the remote sensor on the unit (at a distant of up to 23 feet — 7 m).

1. On the back of the remote control, remove the battery cover.

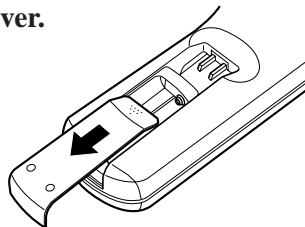

2. Insert batteries. Make sure to match the polarity: (+) to (+) and (-) to (-).

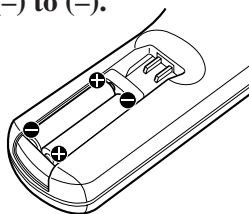

3. Replace the cover.

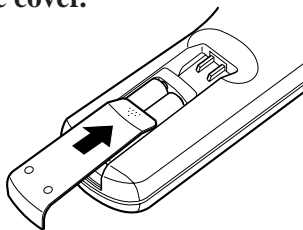

If the range or effectiveness of the remote control decreases, replace the batteries. Use two AAA/R03(UM-4) type dry-cell batteries.

CAUTION:

Follow these precautions to avoid leaking or cracking cells:

- Place batteries in the remote control so they match the polarity: (+) to (+) and (-) to (-).
- Use the correct type of batteries. Batteries that look similar may differ in voltage.
- Always replace both batteries at the same time.
- Do not expose batteries to heat or flame.

Connecting the Unit

You need to connect this unit to an amplifier/receiver and some playback components such as CD player, Compact Component System.

The illustration on the next page indicates a typical connection with a CD player and an amplifier.

Remember NOT to turn on the power until all the connections have been completed.

Analog Connection A

- **For recording on this unit:** Connect an audio cord between the **ANALOG IN jack** on this unit and **Line Output jack** on the playback equipment — e.g. AUX-OUT on an amplifier or LINE OUT on the CD player.
- **For playback or recording on the other unit:** Connect an audio cord between the **ANALOG OUT jack** on this unit and **Line Input jack** (e.g. AUX-IN, CD-R IN, TAPE-IN) on an amplifier or another analog recording component.

Digital Connection — Coaxial B

Connect a coaxial digital cord between the **COAXIAL OUT terminal** on this unit and the **Digital Coaxial Input terminal** (e.g. COAXIAL IN) on an amplifier or another digital recording component.

Digital Connection — Optical C

Before connecting optical cables, disconnect the protective caps from the OPTICAL IN and OUT terminals.

- **For recording on this unit:** Connect an optical digital cord between the **OPTICAL IN terminal** on this unit and the **Digital Optical Output terminal** on a playback component — e.g. OPTICAL OUT on the CD player.
- **For playback or recording on the other unit:** Connect an optical digital cord between the **OPTICAL OUT terminal** on this unit and the **Digital Optical Input terminal** (e.g. OPTICAL IN) on an amplifier or another digital recording component.

Notes:

- It is not required to do all three connections. You can connect your components and this unit using only one or two of the connections listed above.
- It is recommended to use one of the digital connections to obtain the optimum recording quality on this unit.

Turn the power off to all components before connections.

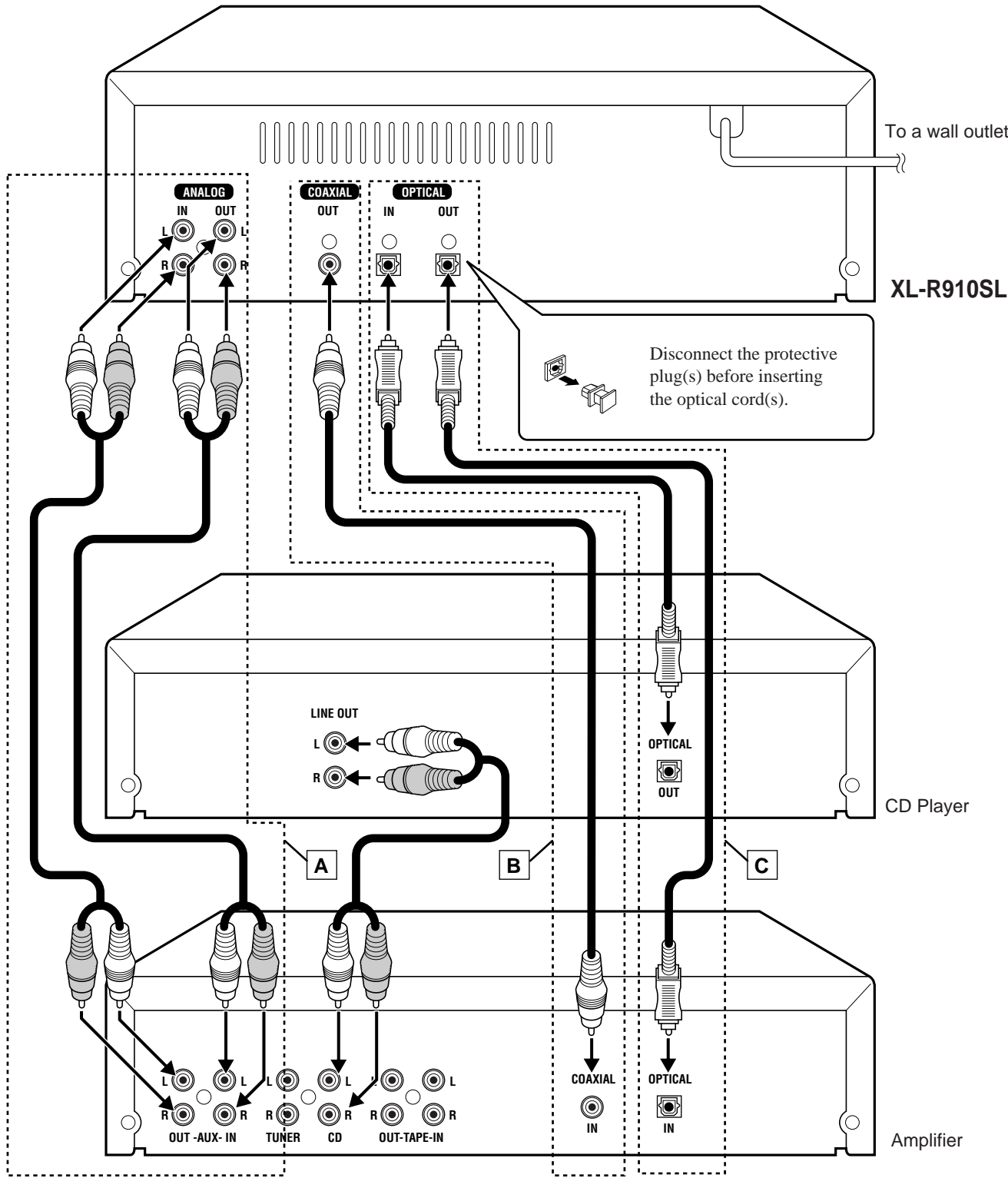

XL-R910SL

CD Player

Amplifier

Disconnect the protective plug(s) before inserting the optical cord(s).

Illustrations of the input/output terminals above are typical examples. When you connect other components, refer also to their manuals since the terminal names actually printed on the rear vary among the components.

CAUTION:
Before plugging the unit into an AC outlet, make sure that all connections have been completed.

Playing Back a Disc

This manual mainly explains operations using the buttons and controls on the front panel. You can also use the buttons on the remote control if they have the similar names (or marks) as those on the front panel. If operations using the remote control are different from those using the front panel, they are then explained.

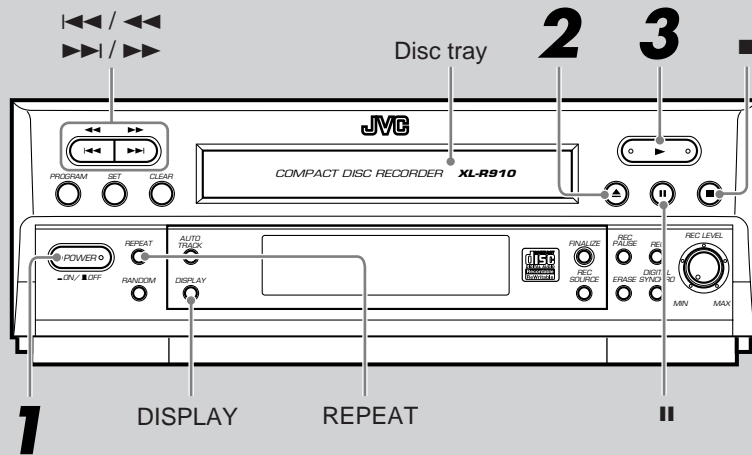

This unit has been designed to play back the following discs:

- Audio CD (CD)
- CD Recordable (CD-R) — both finalized and unfinalized discs
- CD Rewritable (CD-RW) — both finalized and unfinalized discs

1 Turn On the Power



Press POWER to set it to the **ON** position. The display illuminates.

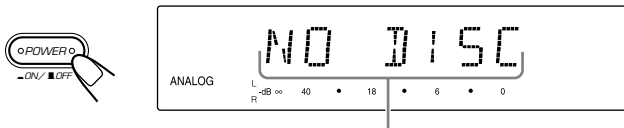

If a disc is already loaded, the total track number and the total playing time appear.

2 Load a Disc

1 Press **▲** to open the disc tray.



2 Insert a disc — CD, CD-R or CD-RW.

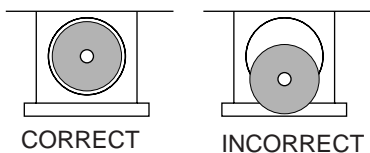

- When using a CD single (8 cm), place it on the inner circle of the tray.

3 Start Playback

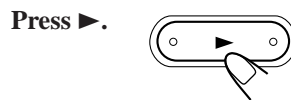

The disc tray automatically closes (“CLOSE” flashes on the display), and the unit starts reading the disc information recorded on the disc (“TOC READ” flashes), then starts playback — Normal Play.

When you have loaded a CD. (See also notes below.)

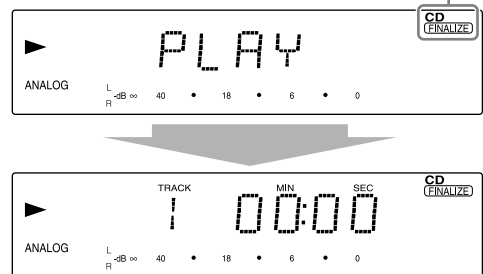

Notes:

- If you have loaded a CD-R, the CD-R indicator lights up. (If the disc is finalized, the FINALIZE indicator also lights up.)
- If you have loaded a CD-RW, the CD-RW indicator lights up. (If the disc is finalized, the FINALIZE indicator also lights up.)

To stop playing, press **■**.

To eject the disc, press **▲**.

To turn off the unit, press POWER to set it in the **OFF** position so that the display goes off.

Basic Playback Operations

While playing a CD, you can do the following operations.

To stop play for a moment

Press **II**.

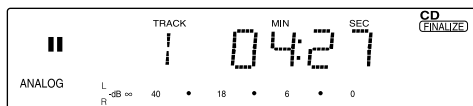

While pausing, the **II** (Pause) indicator lights up on the display.

To resume playback, press **▶**.

To go to another track

Press **◀◀** / **▶▶** or **◀** / **▶** before or during playback.

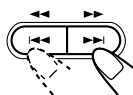

- **◀◀** / **▶▶** : Goes back to the beginning of the current or previous tracks.
- **◀** / **▶** : Skips to the beginning of the next or succeeding tracks.

To locate a particular point in a track

During play, press and hold **◀◀** / **▶▶** or **◀** / **▶**.

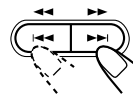

- **◀◀** / **▶▶** : Fast reverses the track.
- **◀** / **▶** : Fast forwards the track.

To go to another track directly using the number buttons



Pressing the number buttons (two digits) on the remote control before or during play allows you to start playing the track number you want.

- Ex.: For track number 5, press 0, then 5.
 For track number 15, press 1, then 5.
 For track number 20, press 2, then 0.
 For track number 32, press 3, then 2.

Note:

You can also select a one-digit number (0 – 9) simply pressing the number button. (Ex.: For track number 5, press 5 then wait for three seconds.)

To check the remaining time

During play or pause, press **DISPLAY**.

- Each time you press **DISPLAY**, the following information appear on the display in sequence.

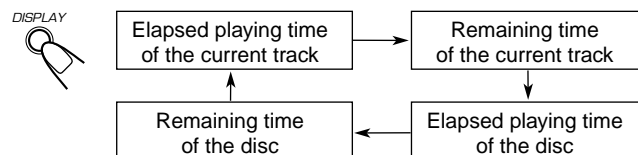

Note:

When you stop playing, this setting is reset. Next time you start playing, the elapsed playing time of the current track will be shown on the display.

To repeat playback

You can have all the tracks in a disc, the program or the individual track currently playing repeat as many times as you like.

To repeat playing, press **REPEAT** during or before play.

- Each time you press the button, Repeat play mode changes as follows, and the following indicator lights up on the display:

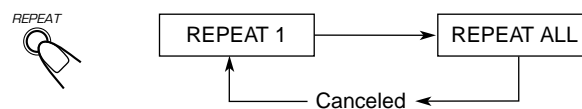

- REPEAT 1 : Repeats one track on a disc or in the program.
- REPEAT ALL : Repeats all the tracks or program.

To cancel Repeat play, press **REPEAT** repeatedly until neither **REPEAT 1** nor **REPEAT ALL** indicator lights up on the display.

Note:

You cannot use the repeat play mode during random play.

- If you start random play, the repeat mode will be canceled.
- If you press **REPEAT** during random play, random playback mode is canceled and normal play resumes.

Selecting Playback Modes

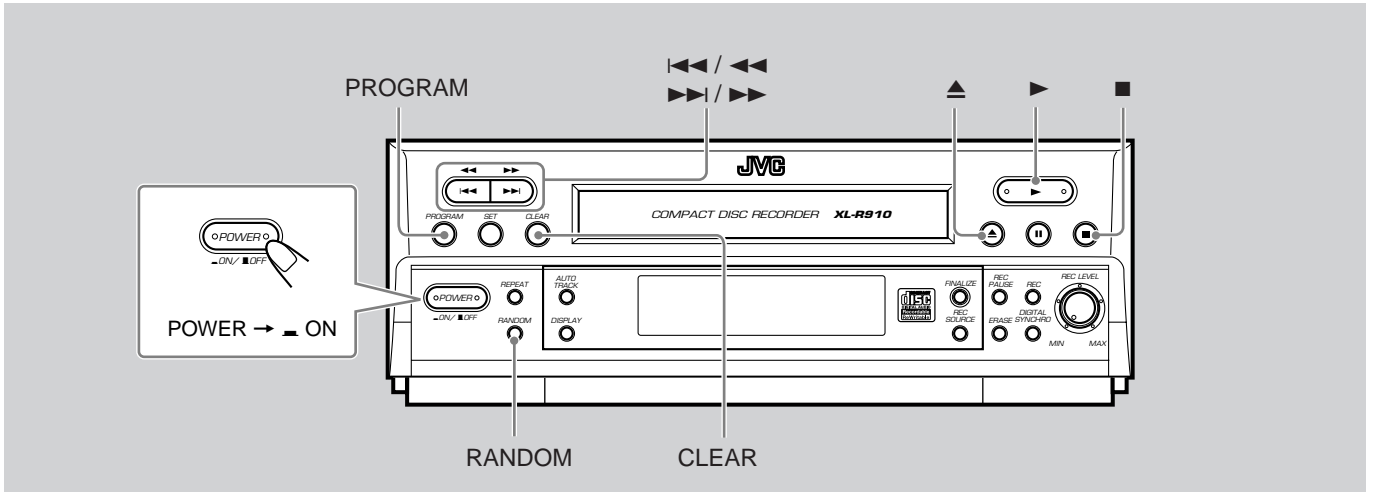

Programming the Playing Order of the Tracks — Program Play

You can arrange the order in which tracks play before you start playing. You can program up to 30 tracks.

- 1 Load a disc.
- 2 Press PROGRAM so that the unit enters program mode.

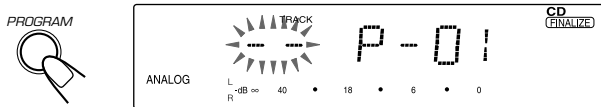

- 3 Press >>>|/|>>> (or <<<|/|<<<) to select a track, then press PROGRAM again.

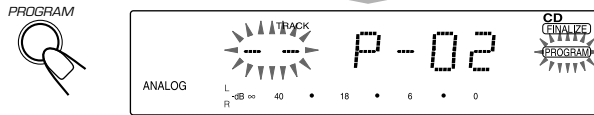
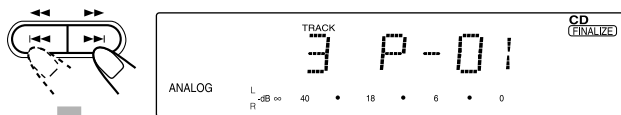

Ex.: Track 3 is stored into program step 1.

- 4 Repeat the above step to program other tracks.

- 5 Press >.

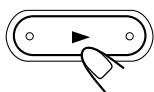

The tracks are played in the order you have programmed.

To stop playing, press ■.

To exit from program play mode, press ■ again or CLEAR before or after play. The PROGRAM indicator goes off. The program you have made is also erased.

- When you press ▲, the program is also erased.

Note:

The display cannot show the hundred digit even if the total playing time exceeds 100 minutes. (e.g. "105:00" will be shown as "05:00.")

To confirm the program contents

Before playing, you can check the program contents by pressing PROGRAM repeatedly. The programmed tracks will be shown on the display in the programmed order.

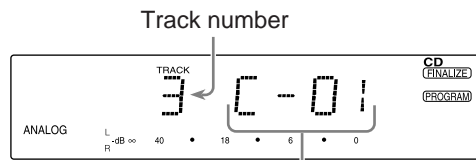

Step number in the program ("C" stands for "Confirm.")

To modify the program

While confirming, you can change the track numbers in the program.

Example: To change the track number (from “18” to “6”) programmed in program step 4

- 1 Press **PROGRAM** repeatedly until the contents of program step 4 appears on the display.

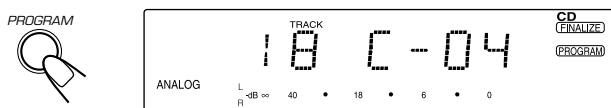

- 2 Press **▶▶|/▶▶** (or **◀◀/◀◀**) to select a new track number, then press **PROGRAM** again.

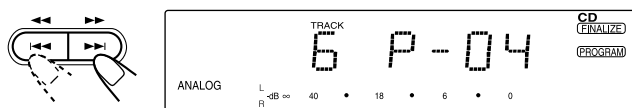

- If you want to erase the track from your program, press **CLEAR**. (In this case, you can see no change on display.)

To add tracks in the program before playing, press **PROGRAM** repeatedly until the unit enters program play mode. (“-” under the TRACK indicator will start flashing on the display), then select the track numbers by following step 3 of the programming procedure (on the previous page).

Playing at Random — Random Play

The tracks will play at random.

1 Load a disc.

- If the unit is in program play mode (the PROGRAM indicator is lit on the display), you cannot go to the next step. If this happens, press **■** to exit from program play mode.

2 Press **RANDOM** so that the unit enters random mode.



The RANDOM indicator lights up on the display.

The tracks are played at random.

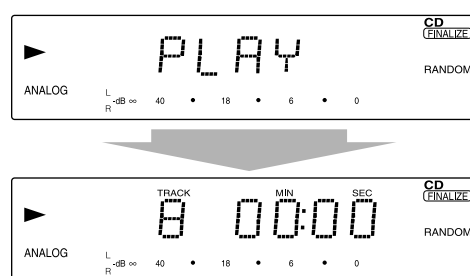

Random play ends when all the tracks are played once.

To skip the currently playing track, press **▶▶|/▶▶** (or **◀◀/◀◀**).

- You cannot go back to the previous tracks during random play even if you press **◀◀/◀◀**.

To stop playing, press **■**.

- Random play mode is also canceled when you press **▲**.

To exit from random play mode, press **RANDOM** again.

- Each time you press the button, random playback mode turns on and off.

Notes:

- You can turn on random playback mode during normal play.
- You cannot repeat random play. If you press **REPEAT** during random play, random playback mode is canceled and normal play resumes.

Recording on a CD-R/CD-RW

Before You Start Recording

- This unit has been designed to record on the following discs — both blank and unfinalized CD Recordable (CD-R) and CD Rewritable (CD-RW).
- **It should be noted that it may be unlawful to re-record pre-recorded tapes, records, or discs without the consent of the owner of copyright in the sound or video recording, broadcast or cable programme and in any literary, dramatic, musical, or artistic embodied therein.**
- The sampling frequency rate converter built in the unit allows you to record a digital source if its sampling frequency is 32 kHz, 44.1 kHz, or 48 kHz. If no playback component is connected to the OPTICAL IN terminal or if the sampling frequency of the connected component is not 32 kHz, 44.1 kHz, or 48 kHz, “UN LOCK” appears on the display (no recording is possible). The sampling frequency indicator (32, 44, 48) lights up to indicate the sampling frequency of the incoming signals through the OPTICAL IN terminal.
- You cannot record the entire Dolby Digital or DTS Digital Surround signals through the OPTICAL IN terminal.
- When you record onto an unfinalized CD-R or CD-RW, its recordings are not erased or overwritten. The recording starts from the point following the last recorded track on the disc.
If you want to record on such a CD-RW from its beginning, you have to erase its contents first (see “Erasing the Tracks on a CD-RW” on page 14. This is only possible on CD-RWs).
- The recording level is automatically set correctly when recording through the digital terminals, so it is not affected by the REC LEVEL control.
- When an unfinalized CD-R or CD-RW is loaded, this unit checks the disc and automatically adjusts the laser for optimum recording setting — Optimum Power Control (OPC).

Using Automatic Tracking while Digital Recording

Press AUTO TRACK so that the AUTO TRACK indicator lights up on the display. A track marking is automatically recorded.

- Each time you press the button, automatic tracking turns on and off.

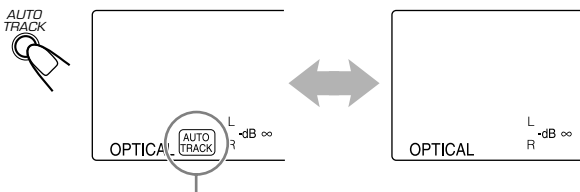

The AUTO TRACK indicator lights up.

When automatic track marking is activated:

Track markings are recorded automatically at the points where the tracks change.

Note:

When “ANALOG” is selected as the recording source (see page 12), automatic track marking is canceled temporarily. (The AUTO TRACK indicator goes off.)

When automatic track marking is deactivated:

No track mark is recorded on a disc. This means that, when playing this disc, this unit (or another CD player compatible with CD-R/CD-RW) will regard the entire recording as one track (track 1). You will not be able to directly select a song or navigate through songs.

To put a track mark manually while recording, press SET at the place you want to put a track mark.



Adjusting the Recording Level through the Analog Input Jacks

Before recording through the Analog Input jacks, adjust the recording level properly.

To adjust the recording level, follow the procedure below BEFORE you start recording procedure described on page 12:

- 1 Start playback on the playback component.
- 2 Check the level indicator on the display while listening to the playback.
- 3 Adjust the REC LEVEL control so that the OVER indicator will never lights up when the highest signal comes in.

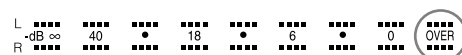
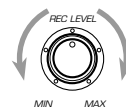

The OVER indicator

Note:

Do not turn the REC LEVEL control while recording; otherwise, recording level will change.

This manual mainly explains operations using the buttons and controls on the front panel. You can also use the buttons on the remote control if they have the similar names (or marks) as those on the front panel.

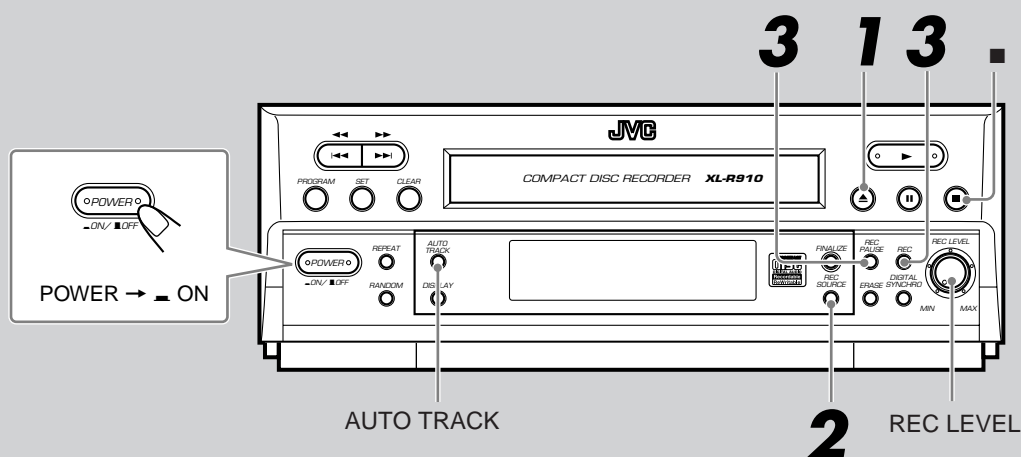

1 Load a Recordable Disc and Prepare the Playback Source

- 1 Press **POWER** to set it to the **ON** position.
- 2 Press **▲** to open the disc tray, and load a disc.
- 3 Press **▲** again to close the disc tray.

The disc tray automatically closes (“CLOSE” flashes on the display), and the unit starts reading the disc information recorded on the disc (“TOC READ” flashes), then the display shows the following.

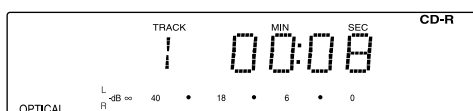

Ex.: When a CD-R is loaded with the recording source (input) set to “OPTICAL”

- 4 Enter the playback component into play pause.
 - Refer also to its Instruction manual — normally, press the Play (▶) button, then soon press the Pause (⏸) button.

2 Select the Recording Source (Input)

Press **REC SOURCE**.

- Each time you press the button, the recording source (input) alternates between “ANALOG” and “OPTICAL.”

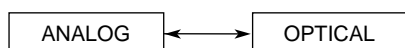

- ANALOG*** : Select this to record through the Analog Input jacks.
- OPTICAL** : Select this to record through the Digital Optical terminal.

Notes:

- If you want to use automatic tracking, see “Using Automatic Tracking while Recording” on page 11.
- * When you select “ANALOG,” you have to adjust the recording level using the **REC LEVEL** control (see page “Adjusting the Recording Level through the Analog Input Jacks” on page 11).

3 Start Recording

- 1 Press **REC PAUSE** to enter the unit into recording pause



The recording pause (⏸) indicator starts flashing on the display.

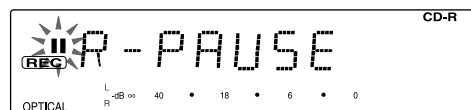

- 2 Press **REC** to start recording.

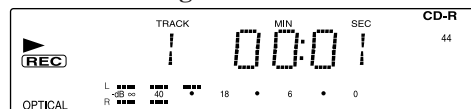

- 3 Start playback on the playback component.

To stop recording, press **■**.

“BUSY” appears when writing the signals on the disc.

- When no sound comes in for 8 seconds while recording through the Analog Input, recording automatically stops.
- If you are to play the disc on another CD player compatible with CD-R/CD-RW, you need to finalize the disc, see “Finalizing a Disc — CD-R/CD-RW” on page 14.

To eject the disc, press **▲**.

To turn off the unit, press **POWER** to set it in the **OFF** position so that the display goes off.

Other Recording Functions

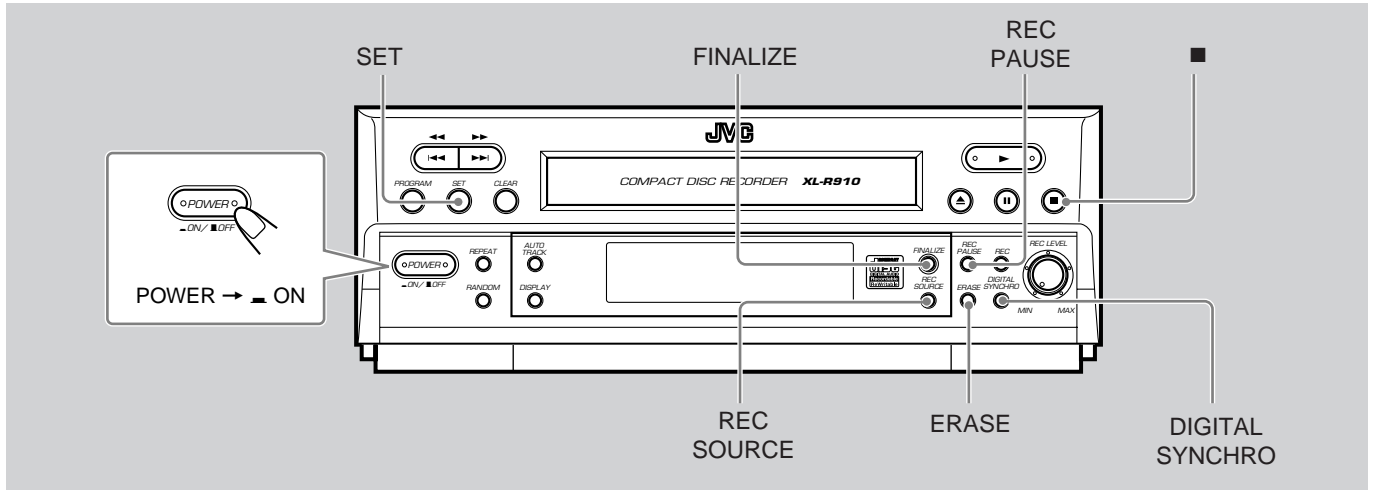

Synchronized Digital Recording

You can use the synchronized recording method when recording through the Digital Optical Input terminal. With this recording method, recording automatically starts when digital signal comes into this unit, and stops automatically when signal stops coming in.

- **One-track recording:** You can record one track at a time. By using this one-track recording, you can record only your favorite songs on one disc.
- **All-track recording:** You can record all the tracks at once.

1 Load a recordable disc and prepare the playback source.

- See page 12 for details.
- If you want to use automatic tracking, see “Using Automatic Tracking while Recording” on page 11.

2 Press REC SOURCE to select the Digital Optical Input as the recording source (the OPTICAL indicator lights up).

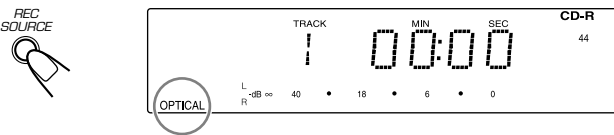

- Each time you press the button, the recording source alternates between “ANALOG” and “OPTICAL.”

3 Press DIGITAL SYNCHRO repeatedly to select either one-track recording or all-track recording.

- Each time you press DIGITAL SYNCHRO, the display changes to show as follows.



- ONE ? : Select this to record only one track.
- ALL ? : Select this to record all the tracks.

4 Press SET.

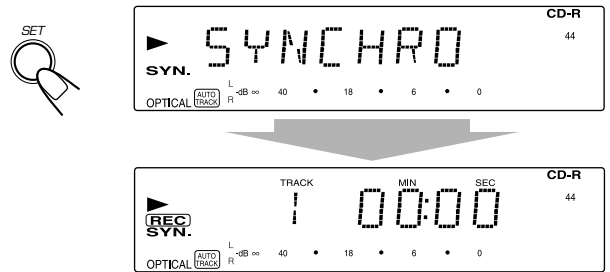

5 Start playback on the playback component.

As soon as signals come into this unit, recording starts on this unit.

- **If you have selected one-track recording,** recording will end when one track is played back. You can continue recording other tracks simply by repeating steps 3 to 5.

To stop any time during recording, press ■. “BUSY” appears when writing the signals on the disc.

Notes:

- If the PROHIBIT indicator lights up when you start playback, you cannot make a recording since duplication of the disc played back is prohibited by SCMS. (See page 15.)
- If you are to play the disc on another CD player compatible with CD-R/CD-RW, you need to finalize the disc, see “Finalizing a Disc — CD-R/CD-RW” on page 14.

Finalizing a Disc — CD-R/CD-RW



Finalization is the final process in recording on a CD-R or CD-RW. “Finalizing a disc” means to finish writing the TOC (Table of Contents) on the recorded disc. Only after this process is completed, a recorded CD-R or CD-RW can be played back on a CD player compatible with CD-R/CD-RW.

IMPORTANT

- Once a CD-R has been finalized, no more recording can be made on the disc.
- If you unplug the power cord or if a power failure occurs during finalization process, recorded data will be lost and the disc may not be utilized any more.

1 Press FINALIZE while a disc you want to finalize is placed on the disc tray.

“FINALIZE?” appears on the display.

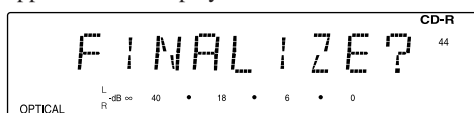

- If you want to cancel finalization, press CLEAR.

2 Press SET to finalize the disc.



The FINALIZE indicator starts flashing on the display.

The finalization process requires about a few minutes to complete (when finalized, the FINALIZE indicator stops flashing and remains lit).

Unfinalizing a Disc — CD-RW



Once a CD-R has been finalized, no more recording will be made on the disc. However, by erasing the TOC (Table of Contents), you can record on a recorded CD-RW. This erasing process of the TOC is called “Unfinalization.”

- Unfinalization is just to erase the TOC only, but not the recorded music signals on the disc.

1 Press REC PAUSE while a disc you want to unfinalize is placed on the disc tray.

“UN FINAL?” appears on the display.

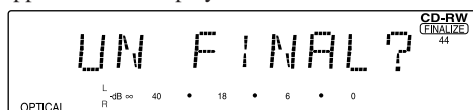

- If you want to cancel unfinalization, press CLEAR.

2 Press SET to unfinalize the disc.



The FINALIZE indicator starts flashing on the display.

The unfinalization process requires about a few minutes to complete (when unfinalized, the FINALIZE indicator goes off).

Erasing the Tracks on a CD-RW



You can erase a track or all the tracks on a CD-RW.

- **One-track erasure:** You can erase the last track.
- **Disc erasure:** You can erase all the tracks at once.

One-track Erasure

1 Load a disc — either a finalized or unfinalized CD-RW.

- If the disc is already finalized, first unfinalize the disc. See “Unfinalizing a Disc — CD-RW” on the left column.

2 Press ERASE repeatedly so that “TRACK ?” appears on the display.

- Each time you press the button, the display alternately shows “TRACK ?” and “DISC ?”

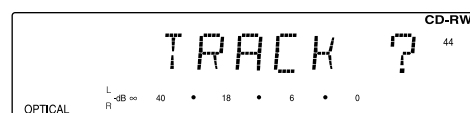

To cancel the erasure, press ■.

3 Press SET.



The ERASE indicator starts flashing and the last recorded track is erased.

4 Repeat steps 2 and 3 to erase the other tracks.

Disc Erasure

1 Load a disc — either a finalized or unfinalized CD-RW.

- If the disc is already finalized, first unfinalize the disc. See “Unfinalizing a Disc — CD-RW” on the left column.

2 Press ERASE repeatedly so that “DISC ?” appears on the display.

- Each time you press the button, the display alternately shows “TRACK ?” and “DISC ?”

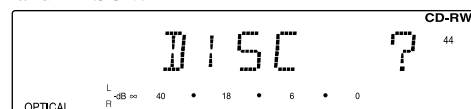

To cancel the erasure, press ■.

3 Press SET.



The ERASE indicator starts flashing and all the tracks on the disc are erased.

Additional Information

Glossary

Finalization

This is the final process in recording on a CD-R or CD-RW. “Finalizing a disc” means to finish writing the TOC (Table of Contents) on the recorded disc. Only after this process is completed, a recorded CD-R or CD-RW can be played back on a CD player compatible with CD-R/CD-RW.

Sampling Frequency

When analog signals are converted into digital signals, they are divided into many points and digitized. This dividing method is called “sampling.” The sampling frequency indicates how many points one second is divided into – for example, for CD sound, one second is divided into 44100 points since its sampling frequency is 44.1 kHz.

SCMS (Serial Copy Management System)

Digital audio components, such as CD recorder, MD (Mini-Disc) recorder and DAT (Digital Audio Tape) recorder, can exchange audio signals in the digital forms through digital input/output terminals. The digital audio components allow digital copy of music signals with little deterioration. This has made it necessary to have a copy restriction rule for protecting the copyright, and “SCMS (Serial Copy Management System)” has been established as a result.

To protect the copyright, the SCMS allows only first-generation digital copies to be made from premastered software (like CDs or prerecorded MDs).

If you try to record from such copied discs on this unit, the PROHIBIT indicator will light up on the display.

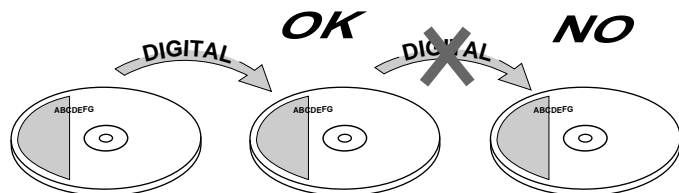

OPC (Optimum Power Control)

OPC is a function that checks the loaded disc and automatically adjusts the laser for optimum recording setting before recording through the Digital Optical Input terminal.

TOC (Table of Contents)

TOC is a kind of disc information containing sub-data (track number, playing time, etc.) that enables us to search for tracks quickly on the disc.

To write the TOC on a CD-R or CD-RW, you need to finalize the disc.

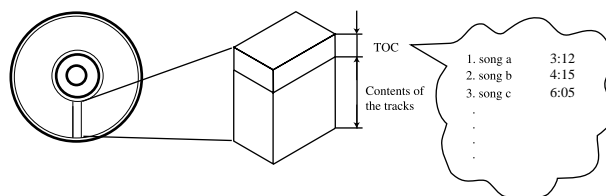

Track mark

When playing a disc, you can move among the tracks. You can do this because there is a mark recorded at the beginning of each track enabling you to locate the track. This mark is called a “track mark” and the portion between two adjacent track marks is called a “track.”

Unfinalization

This means to erase the TOC (Table of Contents) on a finalized CD-RW. This makes it possible to erase the recorded data from the CD-RW.

Handling Discs

How to handle discs

When removing a disc from its case, press down the center holder of the case and lift the disc out, holding it by the edges.

- Always hold the disc by the edges. Do not touch its recording surface.

When storing a disc into its case, gently insert the disc around the center holder (with the printed surface facing up).

- Make sure to store discs into the cases after use.

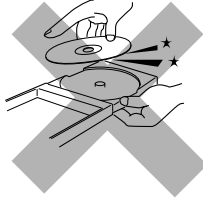

To keep discs clean

A dirty disc may not play correctly. If a disc does become dirty, wipe it with a soft cloth in a straight line from center to edge.



To play new discs

New discs may have some rough spots around the inner and outer edges. If such a disc is used, this unit may reject the disc.

To remove these rough spots, rub the edges with a pencil or ballpoint pen, etc.

Moisture condensation

Moisture may condense on the lens inside the unit in the following cases:

- After starting the heater.
- When the unit is moved from the extremely hot place to the extremely cold place.

Should this occur, the unit may malfunction. In this case, eject the disc and leave the unit turned on for a few hours until the moisture evaporates.

CAUTIONS:

- Do not insert any disc of unusual shape — like a heart or flower; otherwise, it will cause a malfunction.
- Do not expose discs to direct sunlight or any heat source or place them in a place subject to high temperature and humidity. Do not leave them in a car.
- Do not use any solvent (for example, conventional record cleaner, spray, thinner, benzine, etc.) to clean discs.

Troubleshooting

If you are having a problem with your unit, check this list for a possible solution before calling for service.

If you cannot solve the problem from the hints given here, or the unit has been physically damaged, call a qualified person, such as your dealer, for service.

Symptom	Cause	Action
Playback		
No sound is heard.	Unrecorded CD-R or CD-RW has been loaded.	Load a recorded disc.
Playback does not start.	<ul style="list-style-type: none"> • Disc has been loaded upside down. • Condensation occurs on the lens. 	<ul style="list-style-type: none"> • Load it correctly with the label side facing up. • Leave the power on for a few hours until moisture evaporates.
Only a certain portion cannot be played back.	The disc is dirty or scratched.	Clean or replace the disc.
Recording		
Recording is not performed.	<ul style="list-style-type: none"> • CD-R or CD-RW has been loaded upside down. (“NO DISC” appears on the display.) • Finalized CD-R or CD-RW has been loaded. • Source you are trying to copy is a digitally copied disc. (The PROHIBIT indicator lights up.) • Disc is dirty or scratched. 	<ul style="list-style-type: none"> • Replace the disc. • CD-R: Replace the disc. • CD-RW: Unfinalize the CD-RW (see page 14). • Select “ANALOG” as the recording source (input). • Clean or replace the disc.
“UN LOCK” appears on the display.	<ul style="list-style-type: none"> • No digital signal comes in. • No optical digital cord is connected to the OPTICAL IN terminal. 	<ul style="list-style-type: none"> • Source you are trying to copy is a digitally copied disc. • Connect the optical digital cord correctly.
“NO AUDIO” appears on the display.	Loaded CD-R or CD-RW is for computer use.	Replace the disc. Use a disc for music use.
Erasure is not performed.	Disc is damaged.	_____
Remote control		
Operations are disabled.	<ul style="list-style-type: none"> • The path between the remote control and the remote sensor on the unit is blocked. • The batteries are exhausted. 	<ul style="list-style-type: none"> • Remove the obstruction. • Replace the batteries.

If the unit fails to operate properly even when the remedial action suggested above has been taken

This unit uses a microcomputer to perform a large number of operations. If it fails to operate no matter which button is pressed, disconnect the power cord, wait for a few moments, then reconnect it.

IMPORTANT

- If you are going to record something important, always test-record first to check that the recording turns out properly before proceeding with the actual recording.
- The manufacturer assumes no liability whatsoever for any damage resulting from missed opportunity or accidental erasure that occurs while conducting recording or playback operations due to malfunctioning of or trouble in the unit, or for any incidental damage.

CDR section

System: Compact disc digital audio recording system
Sampling frequency: 44.1 kHz
Signal-to-noise ratio: 90 dB
Dynamic range: 90 dB
Frequency response: 20 Hz to 20 kHz
Wow and flutter: Less than measurable limit
Total harmonic distortion: 0.01%

Input:

ANALOG IN: Minimum input level: 300 mV
(Full scale -12 dB)/47 k Ω
OPTICAL IN: Input level: -23 dBm to -15 dBm
(with sampling rate 32 kHz, 44.1 kHz, 48 kHz)

Output:

ANALOG OUT: 2V/50 k Ω (Full scale)
(Full scale -12 dB)/50 k Ω
OPTICAL OUT: Output level: -21 dBm to -15 dBm
(with sampling rate 44.1 kHz)
COAXIAL OUT: 0.5 Vp-p/75 Ω

General

Power requirement: AC 120 V \sim , 60 Hz
Power consumption: 20 W
Dimensions (approx.): 270 mm x 95 mm x 353 mm (W/H/D)
(10¹¹/₁₆ in. x 3³/₄ in. x 13¹⁵/₁₆ in.)
Mass (approx.): 3.8 kg (8.4 lbs)

Supplied accessories
See page 5.

Design and specifications are subject to change without notice.

