



Safety Precautions

FOR USA AND CANADA

	CAUTION RISK OF ELECTRIC SHOCK DO NOT OPEN	
CAUTION: TO REDUCE THE RISK OF ELECTRIC SHOCK, DO NOT REMOVE COVER (OR BACK). NO USER-SERVICEABLE PARTS INSIDE. REFER SERVICING TO QUALIFIED SERVICE PERSONNEL.		



The lightning flash with arrowhead symbol, within an equilateral triangle is intended to alert the user to the presence of uninsulated "dangerous voltage" within the product's enclosure that may be of sufficient magnitude to constitute a risk of electric shock to persons.



The exclamation point within an equilateral triangle is intended to alert the user to the presence of important operating and maintenance (servicing) instructions in the literature accompanying the appliance.

Information for USA

This device complies with part 15 of the FCC Rules. Changes or modifications not approved by JVC could void the user's authority to operate the equipment.

This equipment has been tested and found to comply with the limits for a Class A digital device, pursuant to Part 15 of the FCC Rules. These limits are designed to provide reasonable protection against harmful interference when the equipment is operated in a commercial environment. This equipment generates, uses, and can radiate radio frequency energy and, if not installed and used in accordance with the instruction manual, may cause harmful interference to radio communications. Operation of this equipment in a residential area is likely to cause harmful interference in which case the user will be required to correct the interference at his own expense.

This device complies with Part 15 of the FCC Rules. Operation is subject to the following two conditions: (1) This device may not cause harmful interference, and (2) this device must accept any interference received, including interference that may cause undesired operation.

Due to design modifications, data given in this instruction book are subject to possible change without prior notice.

WARNING:
TO REDUCE THE RISK OF FIRE OR ELECTRIC SHOCK, DO NOT EXPOSE THIS APPLIANCE TO RAIN OR MOISTURE.

AVERTISSEMENT:
POUR EVITER LES RISQUES D'INCENDIE OU D'ELECTROCUTION, NE PAS EXPOSER L'APPAREIL A L'HUMIDITE OU A LA PLUIE.

INFORMATION (FOR CANADA) RENSEIGNEMENT (POUR CANADA)

This Class A digital apparatus complies with Canadian ICES-003.

Cet appareil numérique de la Class A est conforme à la norme NMB-003 du Canada.

WARNING (FOR EUROPE):

This is a Class A product. In a domestic environment this product may cause radio interference in which case the user may be required to take adequate measures.

- This installation should be made by a qualified service person and should conform to all local codes.
- This installation shall be in accordance with the National Electrical Code, ANSI/NFPA 70.
- The unit is to be powered by a DC 12 V or an AC 24 V power supply.
The AC 24 V power supply should conform to the following : Class 2 only (For USA), Isolated power supply only (For Europe).
- Any Mention in this manual of Alarm inputs/ outputs have not been evaluated by UL to be used for Burglar Alarm Functionality.

These are general IMPORTANT SAFEGUARDS and certain items may not apply to all appliances.

IMPORTANT SAFEGUARDS

1. Read all of these instructions.
2. Save these instructions for later use.
3. All warnings on the product and in the operating instructions should be adhered to.
4. Unplug this appliance system from the wall outlet before cleaning. Do not use liquid cleaners or aerosol cleaners. Use a damp cloth for cleaning.
5. Do not use attachments not recommended by the appliance manufacturer as they may cause hazards.
6. Do not use this appliance near water - for example, near a bathtub, washbowl, kitchen sink, or laundry tub, in a wet basement, or near a swimming pool, etc.
7. Do not place this appliance on an unstable cart, stand, or table. The appliance may fall, causing serious injury to a child or adult, and serious damage to the appliance. Use only with a cart or stand recommended by the manufacturer, or sold with the appliance. Wall or shelf mounting should follow the manufacturer's instructions, and should use a mounting kit approved by the manufacturer. An appliance and cart combination should be moved with care. Quick stops, excessive force, and uneven surfaces may cause the appliance and cart combination to overturn.
8. Slots and openings in the cabinet and the back or bottom are provided for ventilation, and to insure reliable operation of the appliance and to protect it from overheating, these openings must not be blocked or covered. The openings should never be blocked by placing the appliance on a bed, sofa, rug, or other similar surface. This appliance should never be placed near or over a radiator or heat register. This appliance should not be placed in a built-in installation such as a bookcase unless proper ventilation is provided.
9. This appliance should be operated only from the type of power source indicated on the marking label. If you are not sure of the type of power supplied to your home, consult your dealer or local power company. For appliance designed to operate from battery power, refer to the operating instructions.
10. This appliance system is equipped with a 3-wire grounding type plug (a plug having a third (grounding) pin). This plug will only fit into a grounding-type power outlet. This is a safety feature. If you are unable to insert the plug into the outlet, contact your electrician to replace your obsolete outlet. Do not defeat the safety purpose of the grounding plug.
11. For added protection for this product during a lightning storm, or when it is left unattended and unused for long periods of time, unplug it from the wall outlet and disconnect the antenna or cable system. This will prevent damage to the product due to lightning and power-line surges.
12. Do not allow anything to rest on the power cord. Do not locate this appliance where the cord will be abused by persons walking on it.
13. Follow all warnings and instructions marked on the appliance.
14. Do not overload wall outlets and extension cords as this can result in fire or electric shock.
15. Never push objects of any kind into this appliance through cabinet slots as they may touch dangerous voltage points or short out parts that could result in a fire or electric shock. Never spill liquid of any kind on the appliance.
16. Do not attempt to service this appliance yourself as opening or removing covers may expose you to dangerous voltage or other hazards. Refer all servicing to qualified service personnel.
17. Unplug this appliance from the wall outlet and refer servicing to qualified service personnel under the following conditions:
 - a. When the power cord or plug is damaged or frayed.
 - b. If liquid has been spilled into the appliance.
 - c. If the appliance has been exposed to rain or water.
 - d. If the appliance does not operate normally by following the operating instructions. Adjust only those controls that are covered by the operating instructions as improper adjustment of other controls may result in damage and will often require extensive work by a qualified technician to restore the appliance to normal operation.
 - e. If the appliance has been dropped or the cabinet has been damaged.
 - f. When the appliance exhibits a distinct change in performance - this indicates a need for service.
18. When replacement parts are required, be sure the service technician has used replacement parts specified by the manufacturer that have the same characteristics as the original part. Unauthorized substitutions may result in fire, electric shock, or other hazards.
19. Upon completion of any service or repairs to this appliance, ask the service technician to perform routine safety checks to determine that the appliance is in safe operating condition.

PORTABLE CART WARNING
(symbol provided by RETAC)



Introduction

Thank you for purchasing this product.

(These instructions are for VN-C205U.)

Before beginning to operate this unit, please read the instruction manual carefully in order to make sure that the best possible performance is obtained.

Contents

Introduction

Contents	4
Characteristics	6
Operating Precautions	6
Operating Environment	8
Latest Updates	8
Name and Function of Parts	9

Preparation

Connection Examples	12
Preparation Procedure	13

Step 1 Connection/Installation

1-1 The flowchart of installation work for camera	14
1-2 Mounting the Camera to the Ceiling	16
1. Preparations	16
Connection to Alarm Input/Output Terminal	18
Inserting the CF card	19
2. Installation	20
Connection of the Input Power Cable	22
3. Adjustment of the camera's angle of view	23
1-3 When installing the Camera to the electrical box	25
1-4 Pull out the cables aside and mount	26
1-5 White-spot correction	26

Settings

Step 2 Network Settings

2-1 Installing the Software	27
2-2 Setting PC's IP Address [Windows XP]	28
Setting PC's IP Address [Windows 2000]	30
2-3 Setting IP Address for this Camera Using the "VN-C205U Setup Tool" ..	32

Step 3 Setting Using the V.Networks Controller

3-1 Starting Up the V.Networks Controller	34
3-2 Features that Allow Setting Using the V.Networks Controller	35

Operation**Step 4 Operating Using the V.Networks Controller**

*For step 4, read "Instruction Manual" (PDF) in the supplied CD-ROM.

Step 5 Operating Using a Web Browser

5-1 Operating Environment	36
5-2 Access Authorization Level	37
5-3 Starting Up the Web Browser	38

Others

Specifications	39
----------------------	----

Introduction

Characteristics

- **The camera uses a high-resolution**
380,000 pixel, high-Sensitivity CCD to realize high picture quality with horizontal resolution of 540 TV lines.
- **Frame Rate**
Supports a maximum frame rate of 30 fps when resolution is 640 x 480 in the JPEG compression format.
- **Supports Multicast**
Support for multicast enables sending of an image data to multiple PCs on the network at one time without lowering the frame rate.
- **Built-in CF (Compact Flash) Slot**
Interface with alarms and enables storage of a recording file in the CF card. Please purchase the CF card separately.
- **Motion Detection Feature**
Enables output of alarm upon detecting motion of images within a specified area.
- **Built-in Web Server**
Enables browsing using the Internet Explorer.

Operating Precautions

- To save energy, turn off the power supply of the system when not in use.
- This camera is intended for indoor use. It cannot be used outdoors.
- Do not install or use the camera in the following locations.
 - Places exposed to rain or water
 - Places containing vapor or oil soot, such as kitchens
 - Places exceeding the operating ambient temperature range (0° to 40°)
 - Places where corrosive gases are generated
 - Places nearby radiation or X-rays as well as sources of strong radio waves or magnetism
 - Places subject to vibration
 - Places with excessive dust
- Insufficient ventilation may cause the camera to malfunction. Be careful not to block ventilation around the camera.
This camera radiates heat from its surfaces (top panel facing ceiling and side panel). Do not install at a location that may trap heat, such as near the walls.
- Do not install at a location that may expose the camera directly to cool air, such as nearby the air outlet of air conditioners. This may cause moisture to condense within the dome cover.
- Dew condensation may occur when there is a drastic change in the ambient temperature of the camera, hence causing a malfunction. When the camera is installed at such locations, turn on the power after allowing it to dry for a few hours.
- Do not point the camera lens at a strong light source such as the sun. Doing so may cause the camera to malfunction.
- This camera contains a built-in AGC circuit. As a result, gain increases at dark places and screen may appear grainy. This is not a malfunction.
- When an equipment that generates a strong magnetic field, such as transceivers, is used near this camera with the AGC turned on, beat noises may appear in the image. When using a transceiver, therefore, place it at least 3 m away from this camera.
- If this camera or cable connected this unit is used near a location where strong electrical or magnetic waves are generated (eg. radios, TVs, transformers, monitors, etc.), noise interference may occur in the image or its color may be affected.
- When this camera is used in the White Balance (ATW) mode, the colors captured may differ slightly from the actual colors due to the operational principles of the auto-tracking white balance circuit. This is not a malfunction.

- When shooting a bright object (eg. lamps, etc.), white vertical streaks may appear on the object on the screen. This is a phenomenon (smear phenomenon) normal to CCDs (solid-state image pickup devices) and is not a malfunction.
- The dome cover is hemispherical in shape, and therefore images tend to be distorted at the edges of the hemisphere. The edges of the hemisphere is masked for this camera. When the camera is tilted and pointed in the horizontal direction, therefore, edges of the hemisphere may enter the angle of view, hence causing the upper end of the screen to appear dark and the image to go out of focus.
- When shooting an object that is near a light source (eg. lightings) or with a large difference in brightness, ghosting may occur on the screen. This phenomenon is due to the characteristics of the dome cover and built-in lens and is not a malfunction.
- Ensure to use the Converter Unit that has been supplied.
- Certain Hubs/switches that are equipped with the SNMP feature may come with a broadcast or multicast control function. Proper viewing of multicast images created by this camera may not be possible if this function is enabled.
- Do not touch the dome cover with your hand. This may dirty the cover and cause the image quality to deteriorate.
- To clean the camera.
 - Do so upon turning off the power.
 - Use a lens cloth (or paper) to remove dirt from the dome cover. The camera may acquire dirt over a short period of time, depending on the environment of use. When there is excessive dirt, wipe using a lens cloth (or paper) upon wetting it in a neutral detergent diluted with water.
- If the D/N switch is turned on, the mode changes automatically to black and white in dark places. As the sensitivity increases, the image may look grainy and white spots may appear. When changing modes, bright portions of image may be emphasized but this is not a failure of the camera.
- The unit is to be powered by a DC 12 V or an AC 24 V power supply. The AC 24 V power supply should conform to the following: Class 2 only (For USA), Isolated power supply only (For Europe).
- The rating label is displayed on the underside of the body.
- JVC will not be liable for any damage resulting from the camera dropping due to incomplete installation by not following the installation instructions. Take caution when performing installation.
- Before starting an important recording, be sure to perform a test recording in order to confirm that a normal recording is possible.
- We do not accept liability for the loss of a recording in the case of it becoming impossible to record due to a problem in the video camera, VCR or video tape.
- We do not accept liability for any damage to the camera in cases when it is dropped because of incomplete installation due to not observing the installation instructions correctly. Please be careful when installing the camera.
- **Read Me**
Please read through the "Read Me" file in the CD-ROM together with this instruction manual.
It is required that the Adobe Reader is installed in the PC.
- Image sending may be affected when this is done on a network where multicast transmission devices are connected, or on networks for which there is transmission of voluminous broadcast data. When this occurs, ensure to employ a system design that separates the camera from other multicast or broadcast devices by making use of a switching valve or VLAN with a multicast control function.
- When using the local recording feature with a CF card, turning off the power during local recording may damage the file. To prevent damage of the file, make use of a UPS (uninterruptible power supply).

 **Warning**

Install at places that are strong enough to support the camera weight.

Install this camera at places that are strong enough to support its weight upon taking into consideration the vibration force during high-speed rotation as well as its mass (approx. 1.0 kg). For ceiling materials that are weak, such as overlay plywood and plaster boards, reinforce by applying reinforcements (veneer plywood). If reinforcement is inadequate, image on the monitor screen may be blurred due to vibrations. In the worst scenario, it may even fall and cause serious injuries if there is someone underneath.

Introduction

Operating Precautions (Continued)

How to Use This Manual

Characters and symbols used in this manual

Caution Points to pay attention to during operation.

Note Details for reference, such as functions or constraints during use.

 Pages or items to refer to.

* JVC shall not be held liable for any loss or damage to the customer or any claim from a third party arising from the use of this software.

Specifications of this software are subject to alteration for improvement without prior notice. All product names that appear in this document are the trademarks or registered trademarks of their respective companies. Marks and symbols such as TM,[®] and [©] do not appear in this document.

Operating Environment

PC Specifications

OS	: Windows 2000 Professional (SP1 or later) Windows 2000 Server (SP1 or later) Windows XP Home Edition (SP1 or later) Windows XP Professional (SP1 or later)
CPU	: Equivalent to or higher than Pentium 3, 500 MHz (Pentium4, 3.2 GHz recommended)
Memory	: 128 MB and above (1 GB recommended)
Hard Disk Space	: 20 MB and above
Display and Video Card	: 1024 x 768 pixels or higher, true color (24 bit or 32 bit) *VRAM 8MB and above (256 MB and above recommended)

LAN Environment

- 10BASE-T/100BASE-TX networks mutually connected by IEEE802.3-compliant Hubs.

CF Card

- Refer to Page 19 for a list of tested CF cards.

Notes

- General users of Windows XP or restricted users of Windows 2000 are not allowed to add/delete V.Networks or change snapshot and recording settings.
- The PC specifications above are only reference values for smooth operation of this application, and are not meant to guarantee operation of this application. Even if the PC satisfies the technical requirements, problems may occur depending on its usage.

Caution

If the OS specifications of the PC to be used are higher, they precede those described above.

Latest Updates

To upgrade the software version or obtain any other latest information, please visit the following website:
<http://www.jvc-victor.co.jp/english/pro/vnetworks/index-e.html>

Name and Function of Parts

Camera

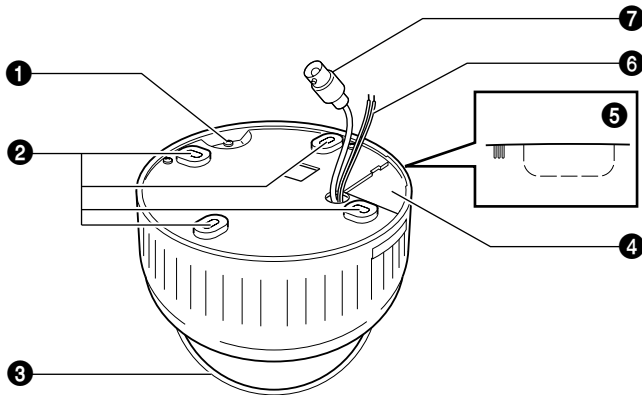

1 Safety cable mounting hole

This hole is mounted to the ceiling slab or channel. (Safety cable not included.)

Caution

To avoid unforeseen accidents, attach the safety cable. Otherwise, there is nothing to prevent the camera from falling should it come loose.

2 Mounting holes

These holes are used to mount the camera body to the ceiling. When using a 4 inch square electrical box, the 2 holes diagonally across are used to fix the box in place.

(☞ Page 21)

3 Dome Cover

The dome cover is fragile. Take care when handling it.

4 Plate for depressing cables

5 Cable extraction hole

This hole is used to extract cables from the side of the camera without opening holes in the ceiling.

6 Input Power cable

To input DC 12 V or AC 24 V power.

The AC 24 V power supply should conform to the following : Class 2 only (For USA), Isolated power supply only (For Europe).

7 Video signal output connector (BNC)

This BNC connector outputs a composite video signal. Connect this to the video input connector of a video monitor, switcher, etc.

(☞ Page 23)

Output is restricted signal in the NTSC format only.

Introduction

Name and Function of Parts (Continued)

Body Surface

View when the dome cover is removed.

For instructions on removing the dome cover, see step 4 of “Mounting the Camera to the Ceiling”. (☞ page 17)

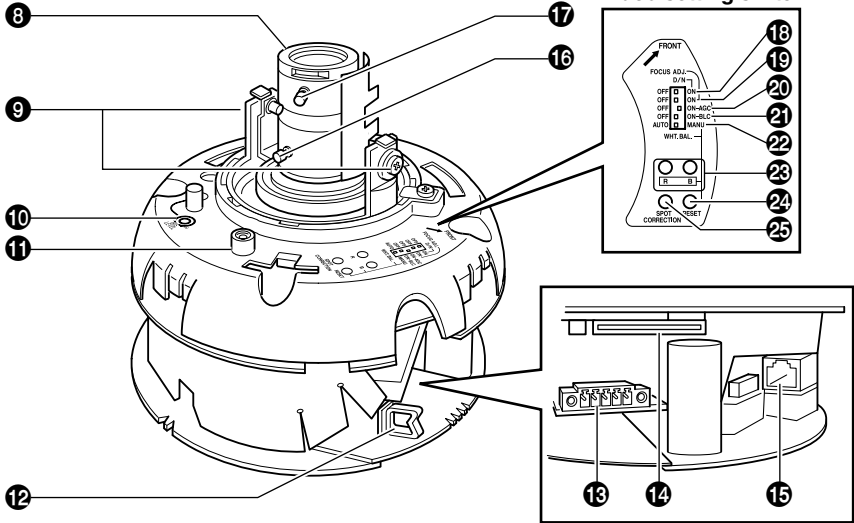

8 Head

For adjusting the lens, focus, or camera angle. (☞ page 23 to 24)

9 Tilt lock screws

Use when adjusting the angle of view of the camera. (☞ Page 23)

10 [IRIS LEVEL] Iris level adjustment

For adjusting the level of the automatic aperture control lens. This adjustment only needs to be made when required. Use this to accommodate particular shooting conditions.

	Turning direction of level
To darken image	Counterclockwise (L side)
To brighten image	Clockwise (H side)

Note

- When adjusting the iris level, set the AGC switch to “OFF”. Otherwise, when the level is turned too far toward L, the AGC function activates increasing sensitivity and the picture may look uneven.

11 MONITOR terminal (RCA pin)

For connecting a monitor when mounting the camera for adjusting the lens or determining the camera angle. (High impedance)

12 Wire clamp

When pulling out the cables from the side of camera unit without opening a hole on the ceiling, arrange the all the cables by bundling them into this wire clamp.

13 [ALARM IN/OUT] Alarm Input/Output Terminals

Terminals for alarm input and output. (☞ Page 18)

14 CF card Slot

Insert the CF card. (☞ Page 19)

15 [10BASE-T/100BASE-TX] 10BASE-T/100BASE-TX Terminal

This is a 10BASE-T/100BASE-TX terminal. It is used for connecting to the network via LAN cables. (☞ Page 20)

Pin No.	Signal Name	
1	Alarm Output	Alarm Output 1
2		Alarm Output 2
3	Alarm Input	Alarm Input 1
4		Alarm Input 2
5	GND	

16 Focal length adjustment ring

Use the fastening screw adjustment ring to set the image size and fix it with fastening screw. (☞ Page 24)

17 Focus ring

Use the fastening screw adjustment ring to set the focus and fix it with fastening screw. (☞ Page 24)

Video setting switch

18 [D/N - ON/OFF] Easy Day & Night switch

To capture a subject with continually changing brightness (day/night), set this switch to "ON". The camera automatically captures the image in color when the subject is bright, and in black and white mode when it is dark. (Default setting: OFF)

Caution

The Easy Day & Night feature on this camera uses a sensitized black and white mode unlike other black and white surveillance cameras that use infra-red lighting.

19 [FOCUS ADJ. - ON/OFF] focus adjustment switch

When adjusting the focus during installation, setting this switch to "ON" will open the iris. (Default setting: OFF) (☞ page 24)

20 [AGC - ON/OFF] Auto-gain control switch
Setting this switch to "ON" automatically increases the sensitivity even when the brightness of the subject is insufficient. (Default setting: ON)

21 [BLC - ON/OFF] Backlight Compensation switch
Setting this switch to "ON" opens the iris even in backlight conditions, making the subject easier to view. (Default setting: OFF)

22 [AUTO/MANU] White Balance Automatic/Manual switch
For selecting whether to adjust the white balance automatically or manually. (Default setting: AUTO)

23 [R/B] Manual WHITE adjustment button
This button is pressed when manually adjusting the white balance. This feature is enabled when the "MANU" is selected using 22 [AUTO/MANU] switch. Press the B button to increase the blue tint and decrease the red tint.

24 [RESET] Manual WHITE reset button
When this button is pressed, the value of the white balance adjusted manually is reset to the default value.

25 [SPOT CORRECTION] White-spot correction button
When this button is pressed, white spots are corrected. For instructions on correcting white-spots, see "About White-spot correction". (☞ page 26)

Preparation

Connection Examples

LAN Connection

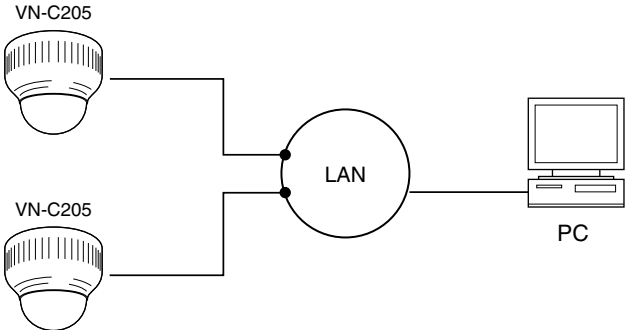

Internet Connection

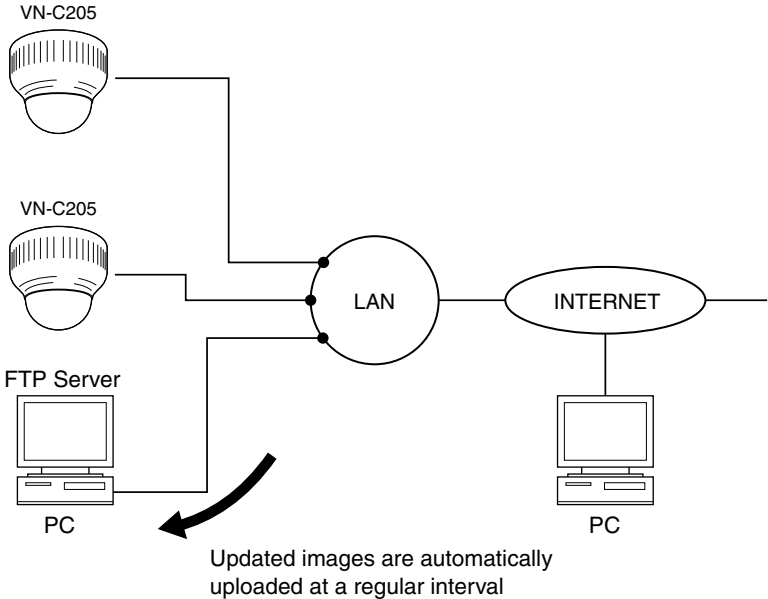

Peer-to-Peer Connection

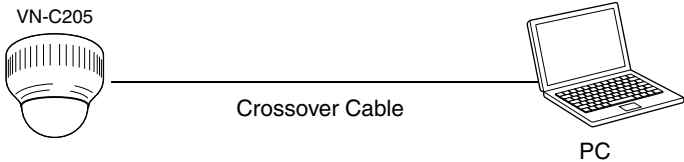

Preparation Procedure

Set the camera in the following procedure.

Step 1 Connection/Installation

Firstly, make a hole in the ceiling, followed by connecting the input power cable, LAN cable or alarm signal cable to the terminal of this camera.

 Page 14

Next, attach the camera to the ceiling. Do not forget to attach the safety wire.



Step 2 Network Settings

Install the software, set the network for this camera as well as using the "VN-C205U Setup Tool", and register the connected camera with the "V.Networks Controller".

 Page 27



- In a system where more than 1 VN-C205 is used, turn on the power for a VN-C205 first, followed by setting the camera until "2-3 Setting IP Address for this Camera Using the 'VN-C205U Setup Tool' " is completed. Upon doing so, turn on a second camera and perform setting in the same way. Perform the same procedure for subsequent cameras.

( Page 22)

Step 3 Setting Using the V.Networks Controller

Perform settings for Image Quality and Alarm using the "V. Networks Controller" software that has been installed.

 Page 34



Step 4 Operating Using the V.Networks Controller

The "V. Networks Controller" can also be used to perform recording/playback operations.

 For details, refer to the PDF instruction manual inside the supplied CD-ROM.



Step 5 Operating Using a Web Browser

Operation is possible via a web browser.

 Page 36

Preparation (Step 1 Connection/Installation)

1-1 The flowchart of installation work for camera

Getting Started

Caution

Attachment of an embedded cover in the ceiling (recess bracket) may be mandatory in certain regions. If this is so, ensure that the embedded cover (recess bracket) is securely attached before installing the camera. (☞ Page 16)

1. Preparation

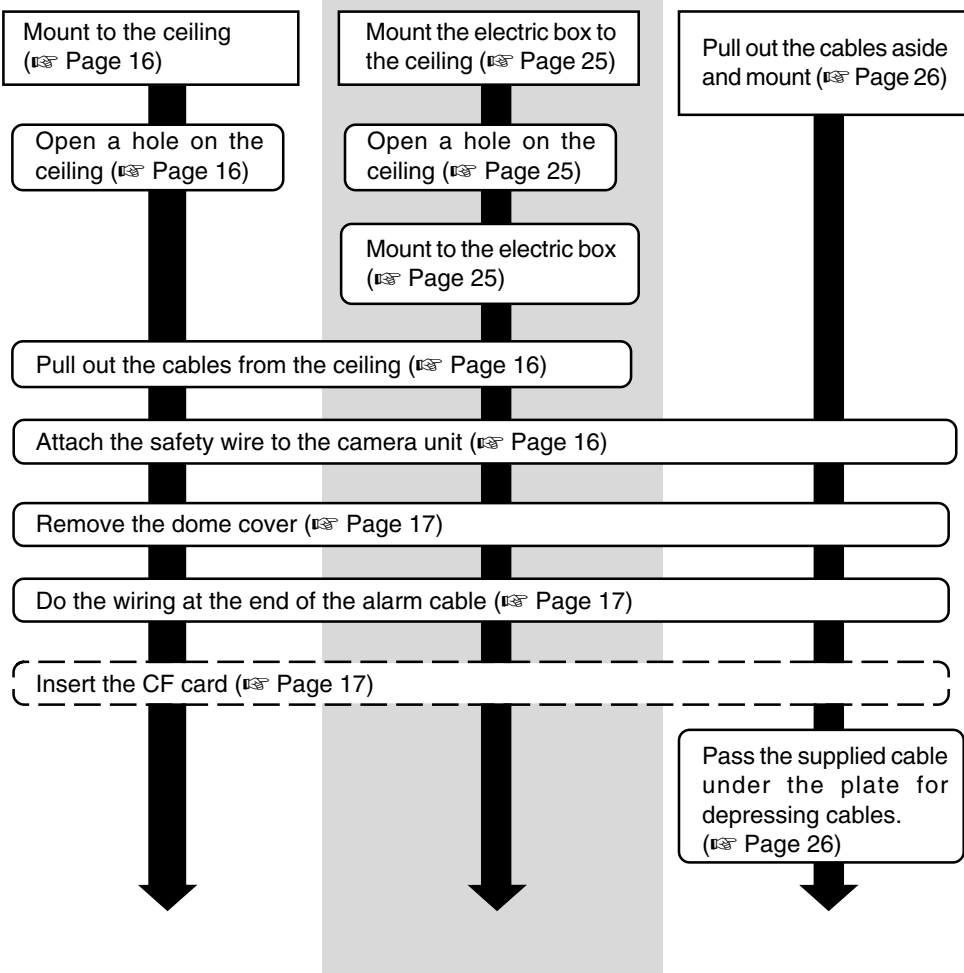

2. Installation

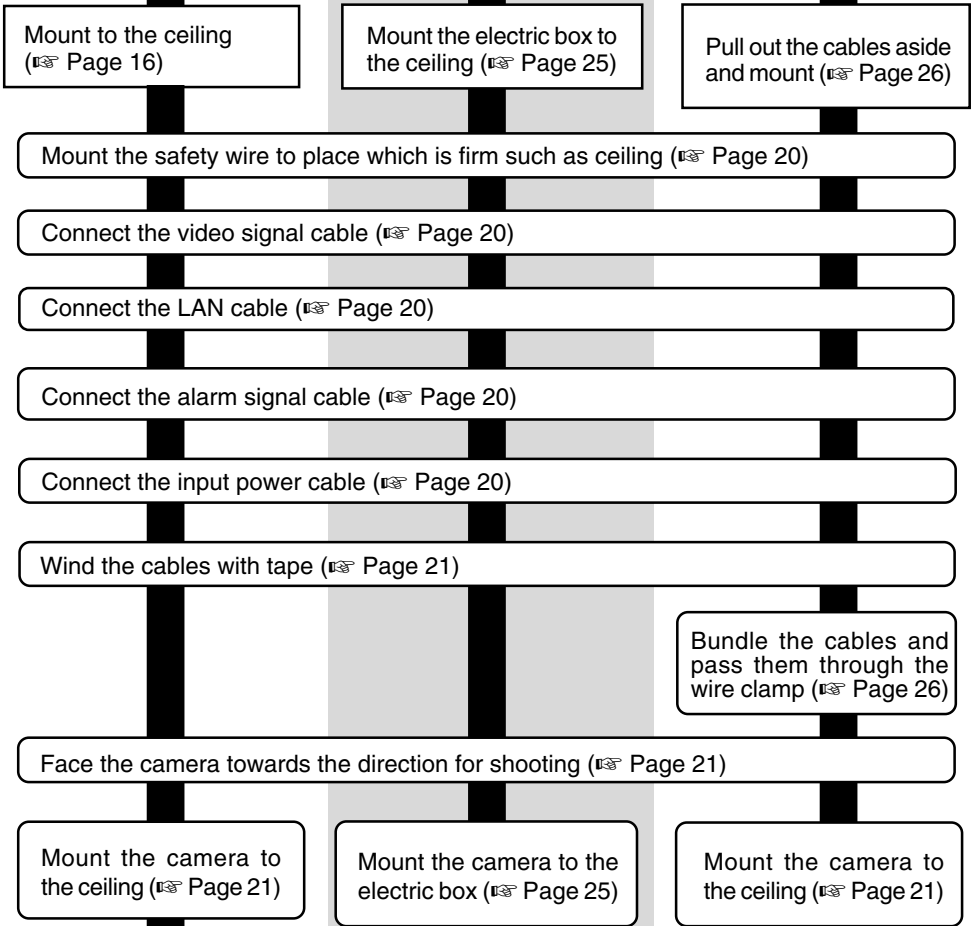

3. Adjustment of the camera's angle of view

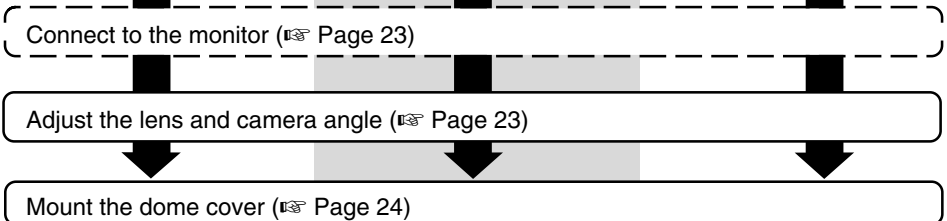

Preparation (Step 1 Connection/Installation)

1-2 Mounting the Camera to the Ceiling

Cautions

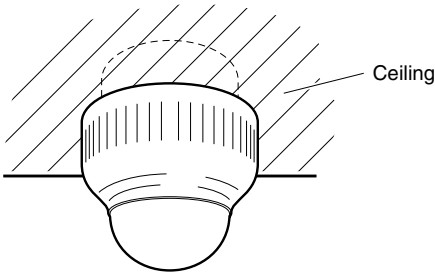

Embedded Cover in Ceiling (recess bracket)

- Attachment of an embedded cover in the ceiling (recess bracket) may be mandatory in certain regions. If this is so, ensure that the embedded cover (recess bracket) is securely attached before installing the camera.
- Please refer to the instruction manual for the cover in use for details on installation of the embedded cover (recess bracket).
- For more detail, please contact the JVC.

1. Preparations

Open hole in ceiling, connect cables and mount camera to ceiling.

1.

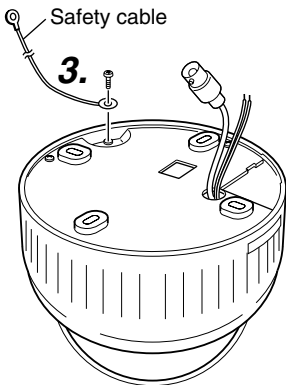
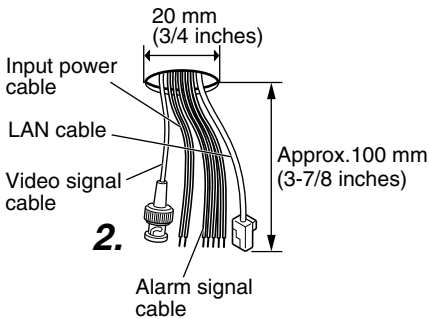

1. Open a hole in the ceiling.

Use the template and open a hole in the ceiling for the cables.

Note

There is no need to open a hole in the ceiling when using the cable extraction hole on the side of the camera. (Refer to step 4. on page 17)

2. Pull out the cables from the ceiling.

Before connecting, pull out the input power cable and video signal cables about 100mm (3-7/8 inches) from the ceiling.

3. Attach the safety cable to the camera. (Safety cable is not included)

Attach the safety cable to the back of the camera.

Cautions

- To avoid unforeseen accidents, attach the safety cable.
- Select a suitable safety cable based on length, strength, location, material (insulation property), etc.
- Always use the M2.6 x 6 screws mounted on the unit.

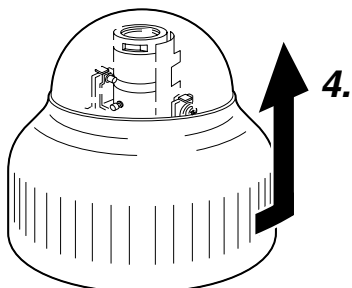

4. Remove the dome cover.

Turn the dome cover anticlockwise and remove it as shown in the diagram.

* When pulling out the cables to mount the camera, press the perforations of the dome cover with finger to open the hole for pulling out the cables. (☞ Page 9)

5. Do the wirings for the alarm cable

Remove the terminal block of the alarm cable from the camera unit and do the wirings.

(☞ Page 18)

6. Insert the CF card into the camera unit

Insert the CF card into the camera unit when necessary. (☞ Page 19)

Preparation (Step 1 Connection/Installation)

1-2 Mounting the Camera to the Ceiling (Continued)

1. Preparations (Continued)

■ Connection to Alarm Input/Output Terminal

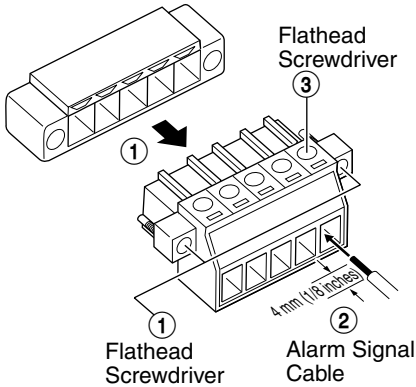

Connect the alarm input/output terminals to external devices such as sensors and buzzers.

- ① Loosen the screws on both edges of the terminal block using a flathead screwdriver, followed by dismantling it as shown in the left diagram.
- ② Strip the coating of the alarm signal cable by about 4mm (1/8 inches) before inserting it into the terminal.
- ③ Turn the screw on the side to fasten the alarm signal cable.

* Connect the alarm terminal according to step 4 of “2 Installation.” (☞ Page 20)

Note

Cable Specifications

- 50 m or shorter in length
- UL1007, UL1015 or equivalent
- AWG#22 to AWG#18 or equivalent

Caution

Due to external noise, the cable may not function properly even when the cable length is less than 50 m. In this case, use a shielded cable or take measures such as keeping the cable away from the noise source.

● Alarm Input Terminal

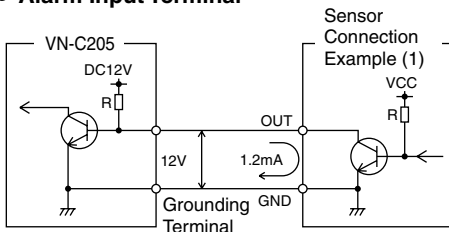

(Alarm Input Equivalent Circuit)

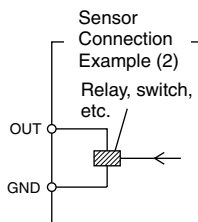

Connect this terminal to an infrared, door or metallic sensor, or to a manual switch.

Input Requirements

- No-voltage relay or NPN open collector input
- The polarity of input detection can be selected via software
- Make/Break/Toggle (at least 250 ms)
- Circuit current at low-level: 1.2 mA
- Voltage applied at high level: 12 V

● Alarm Output Terminal

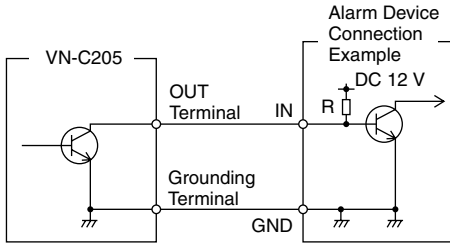

(Alarm Output Equivalent Circuit)

Connect this terminal to alarm devices such as an annunciator, indicator, lamp or buzzer.

Output Requirements

- Equivalent to NPN open collector output (Set output logic using the controller)
- Allowed applied voltage: DC12V and below
- Allowed input current: 50 mA
- Momentary output: 1 to 5000ms (Set duration using the controller)

Caution

Connect the grounding terminal of VN-C205 to the GND terminal of the alarm device.

■ Inserting the CF card

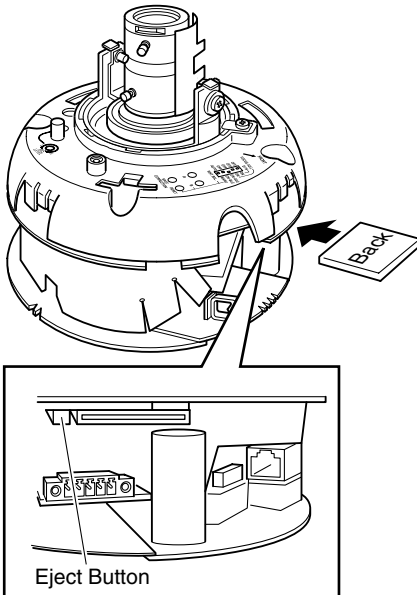

Insert CF card in the direction as indicated in the diagram

- Press once if the eject button is protruding
- Insert the CF card all the way until you hear a "click" sound

* When removing the card, ensure that the power of the camera is turned off before pressing the eject button.

<List of Tested CF Cards>

- **San Disk (Industrial)**
 - 128MB (SDCFBI-128-201-80)
 - 256MB (SDCFBI-256-201-80)
 - 512MB (SDCFBI-512-201-80)
 - 1024MB (SDCFBI-1024-201-80)

Preparation (Step 1 Connection/Installation)

1-2 Mounting the Camera to the Ceiling (Continued)

2. Installation

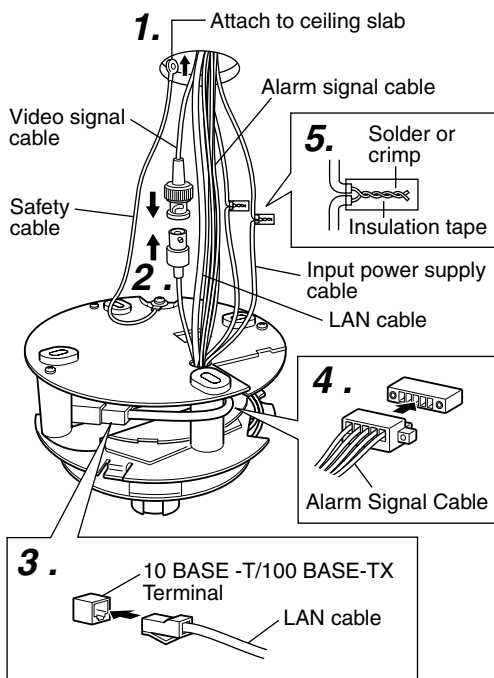

1. Attach the safety cable to the ceiling slab. (Safety cable not included)

Attach the safety cable that has already been attached to the camera to the ceiling slab or channel. Make sure that the wire is attached securely.

2. Connect the video signal cable.

Connect the coaxial cables (BNC) to the video signal output connector (BNC).

Cable	Maximum length (No cable compensator)
RG-59	200m (650 ft)
RG-6	350m (1140 ft)
RG-11	450m (1470 ft)

3. Connect the LAN cable

Pass the LAN cable coming out from the ceiling under the plate for depressing cables, connect it to the 10BASE-T/100BASE-TX Terminal of the camera unit.

Caution

The use of a crossover cable may not be supported by certain LAN boards on some rare occasions. As such, please check your LAN board specifications before connection.

Note

When using 100 BASE-TX, ensure to use a Category 5 (or higher) cable.

4. Connect the alarm terminal

Connect the alarm cable wired in step 5 of Preparations (☞ page 17) to the alarm terminal of camera unit. Pass the cable under the plate for depressing cables same as step 3 before connecting.

5. Connect the input power supply cable.

Connect the cable protruding from the ceiling to the input power cable. (☞ Page 22)

Note

The input power cable uses materials similar to those of machinery wiring, so wrap the cable with insulation tape to prevent it from becoming damaged when mounting the camera. Use durable wiring for the input power cable.

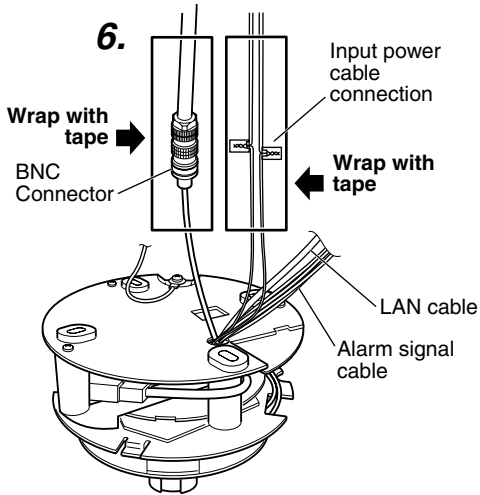

6. Wrap insulation tape around cables.

As shown in the diagram to the left, wrap insulation tape around the input power cable connection and BNC connector. Insert the cables into the hole in the ceiling.

Note

Wrapping the wires with insulation tape improves handling as well as reducing interference.

7. Point the camera in the direction you wish to capture.

Point the camera so that the Horizontal Lock screw is facing the direction you wish to capture. The camera can be adjusted $\pm 60^\circ$ horizontally to either side of the Horizontal Lock screw.

8. Mount the camera to the ceiling.

Use M4-sized (No. 8) screws/bolts or wood screws ($\phi 4.1\text{mm}$, 1/8 inches) to secure the camera in four places when mounting to the ceiling or wall.

Caution

Tighten all screws securely. Otherwise the camera may come loose and fall.

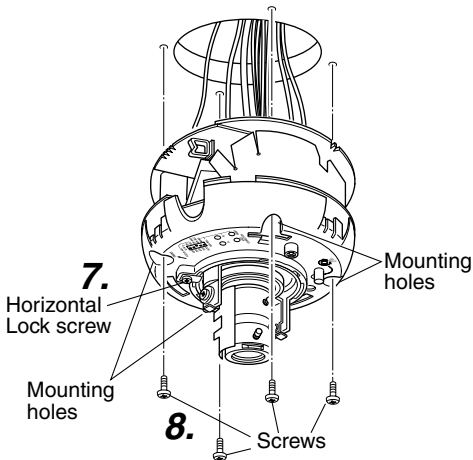

Preparation (Step 1 Connection/Installation)

1-2 Mounting the Camera to the Ceiling (Continued)

2. Installation (Continued)

■ Connection of the Input Power Cable

Be careful of the following items when connecting the cables.

- Turn OFF the power supply to all components before making connections.

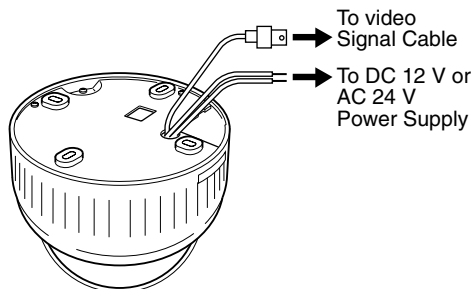

■ DC 12 V or AC 24 V Input power cable

Connect the DC 12 V or the AC 24 V power supply to the DC 12 V/AC 24 V terminals on the terminal board. To prevent connection errors or a cable disconnection, we recommend the use of lug plates for the connections.

The following table shows the connection distances and connection cables provided that 2-conductor VVF cables (vinyl-insulated vinyl sheath cables) are used.

Conductor diameter (mm)		ø1.0 mm (AWG18)	ø1.6 mm (AWG14)	ø2.0 mm (AWG12)
Maximum extension	DC 12 V	20 m (60 ft)	70 m (220 ft)	110 m (360 ft)
	AC 24 V	70 m (220 ft)	180 m (590 ft)	280 m (910 ft)

Cautions

- If thin cables are used (i.e. with a high resistance), a significant voltage drop will occur when the unit is at its maximum power consumption. Either use a thick cable to restrict the voltage drop at the camera side to below 10%, or place the power supply near to the camera. If voltage drop occurs during operation, the performance will be unstable.
- Do not allow input from both a DC 12 V and AC 24 V power supply at the same time.
- When using a DC 12 V power supply, ensure that the polarities of the cable are correct.
- The AC 24 V power supply should conform to the following:
For USA : Class 2 only
For Europe : Isolated power supply only

Note

Connecting multiple VN-C205 Cameras

In a system where more than 1 VN-C205 is used, turn on the power for a VN-C205 first, followed by setting the camera until "2-3 Setting IP Address for this Camera Using the 'VN-C205U Setup Tool'" is completed. Upon doing so, turn on a second camera and perform setting in the same way. Perform the same procedure for subsequent cameras.

- Default IP address setting for all VN-C205 cameras is 198.168.0.2. When the power for multiple cameras are turned on at one time under a single LAN environment, therefore, proper access may not be established due to IP address redundancy. Do not turn on the power of more than 1 camera at the same time.
- When IP address redundancy occurs, ensure that only one VN-C205 exists under a single LAN environment, and wait for some time (at least 10 minutes). In some cases, the power for all network devices under the same LAN environment may have to be turned off and on again to enable access to VN-C205.

3. Adjustment of the camera's angle of view

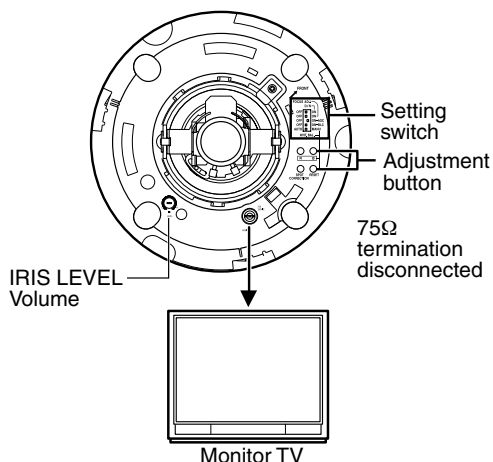

1. Connection for Adjustment of the Camera

The MONITOR terminal is used when making various adjustments to the camera at installation.

The power to the camera body must be ON when adjustments are performed.

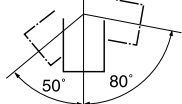
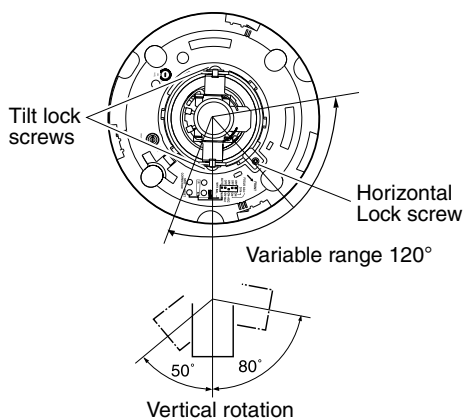

Vertical rotation

Focal length adjustment ring IRIS LEVEL

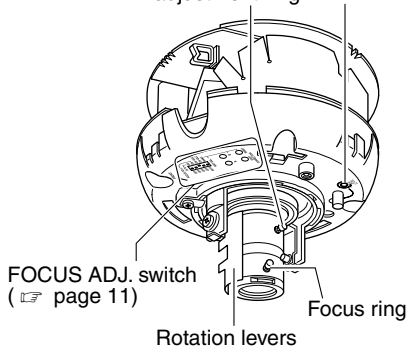

2. Adjusting the Lens and Camera Angle

Camera angle, zoom and focus are adjusted.

● Horizontal rotation (adjustable range: 120°)

- ① Loosen the horizontal LOCK screw.
- ② Holding the both tilt lock screws, rotate horizontally.
- ③ Tighten the horizontal LOCK screw.

● Vertical rotation (adjustable range: +80°, -50°)

- ① Loosen the tilt lock screws.
- ② Holding the rotation levers, rotate vertically.
- ③ Tighten the tilt lock screws.

● Image inclination (adjustable range: ±15°)

Manipulate the rotation levers to adjust the inclination of the image.

● Adjusting the iris level

This adjustment only needs to be made when required. (page 10)

Preparation (Step 1 Connection/Installation)

1-2 Mounting the Camera to the Ceiling (Continued)

3. Adjustment of the camera's angle of view (Continued)

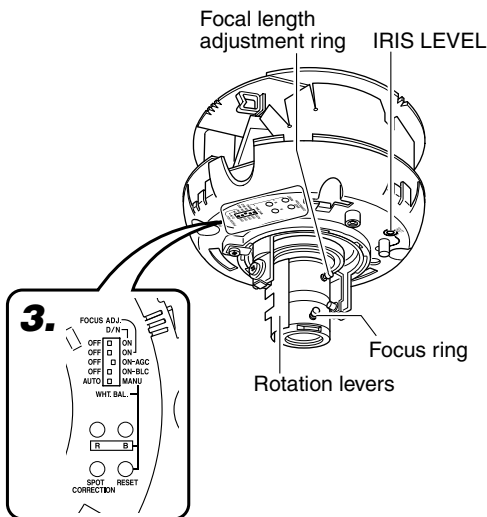

● Adjusting the focal length

- ① Turn the securing screw of the focal adjustment ring counterclockwise.
- ② Adjust the focal length.
- ③ Turn the securing screw clockwise to secure the focal adjustment ring.

● Adjusting the focus

Adjust using the focus ring.

- ① Set the FOCUS ADJ. switch to "ON".
The aperture is opened, decreasing the depth of field, making it easier to adjust the focus.
- ② Adjust the focus.
* Repeat steps 1 to 3 of "Adjusting the image size" and "Adjusting the focus".
- ③ After adjustment is complete, set the FOCUS ADJ. switch to "OFF".

3.Settings related to video

Perform the settings using "Video setting switch" (☞ page 11) if necessary.

Note

Settings related to video can only be performed using "Video setting switch" on the camera unit. Changes cannot be performed via the network.

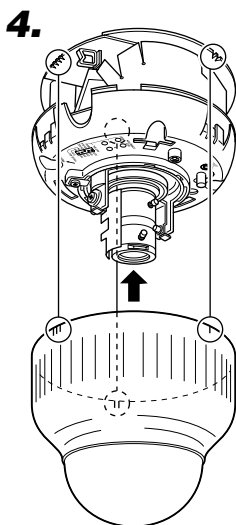

4.Attach the dome cover

Set the dome cover to the unit by aligning the 3 marks on the camera and dome cover (I, II and III). Be sure a click is heard.

CAUTION

Be sure that the dome cover is firmly attached. Improper attachment could result in the cover dropping down.

1-3 When installing the Camera to the electrical box

The camera can be mounted directly onto an electrical box.

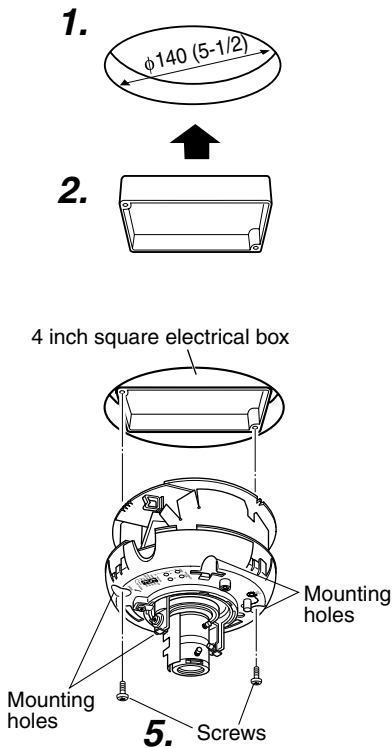

1. Open a hole in the ceiling.

Open a 140mm (5-1/2 inches) hole in the ceiling.

2. Mount the electrical box.

The camera can be mounted on a 4-inch square electrical box.

For instructions on mounting the electrical box, ask your dealer.

3. Follow steps 2 to 6 of mounting the Camera to the Ceiling (Preparations)

(☞ page 16)

4. Follow steps 1 to 7 of mounting the Camera to the Ceiling (Installation)

(☞ page 21)

5. Mount the camera to the electrical box.

Secure the camera to the electrical box using two mounting holes.

6. Follow "Mounting the Camera to the Ceiling (Adjustment of the camera's angle of view)".

(☞ page 23)

Preparation (Step 1 Connection/Installation)

1-4 Pull out the cables aside and mount

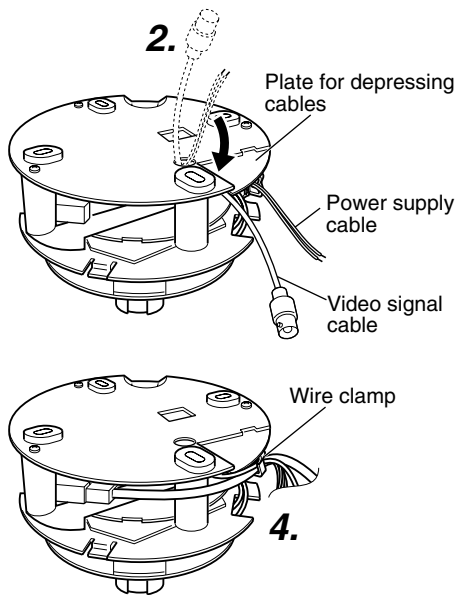

1. Follow steps 3 to 6 of mounting the Camera to the Ceiling (Preparations) (☞ page 16)

2. Pass the input power cable and video signal output cable provided with the camera unit under the plate for depressing cables.

3. Follow steps 1 to 6 of mounting the Camera to the Ceiling (Installation) (☞ page 20)

4. Bundle all the cables into the wire clamp
Bundle the cables coming out from the ceiling (Video signal cable, Input Power cable, LAN cable and alarm signal cable etc.) into the wire clamp.

5. Follow steps 7 to 8 of mounting the Camera to the Ceiling (Installation) (☞ page 21)

6. Follow “Mounting the Camera to the Ceiling (adjustment of the camera’s angle of view)”. (☞ page 23)

1-5 White-spot correction

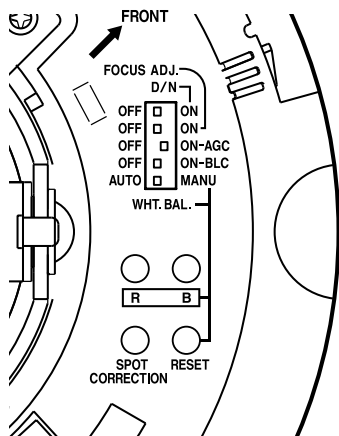

As a general characteristic unique to CCDs, white-spots may appear on the screen with age. In order to reduce this phenomenon, this unit is equipped with a white-spot correction feature.

Switch on the camera power supply and wait for at least 30 minutes.

1. Remove the dome cover.
2. Cover the lens surface using a black sheet of paper, etc. so that light does not enter the lens.
3. Press and hold the SPOT CORRECTION button on the unit for more than 2 seconds.

* White-spot correction will start. Correction may take several seconds for completion.

Notes

- Maximum correction: less than 16 to 32 spots
- The white-spot correction feature of this unit does not guarantee the correction of all white spots. Depending on the characteristic of white spots, correction may not be possible.
- When performing white-spot correction, accurate data may not be achieved in case of highly detailed pixels since correction is made using the information of surrounding pixels.
- The result of white-spot correction is maintained until the next correction is performed.

Settings (Step 2 Network Settings)

2-1 Installing the Software

To operate this camera, you will have to install the necessary software according to the following procedure from the CD-ROM supplied.

Installing the V.Networks Controller

1. Execute "Setup.exe" in the [JVC] folder.
2. Follow instructions on the screen to install the software.
3. If installation is successful, the → "V.Networks Controller" icon will be displayed in the [Start] → [Programs]  [V. NETWORKS] folder.

Installing the VN-C205U Setup Tool

1. Execute "Setup.exe". This is located inside the [Setup] folder of the [JVC] folder.
2. Follow instructions on the screen to install the software.
3. If installation is successful, the → "VN-C205U Setup Tool" icon will be displayed in the [Start] → [Programs]  [V. NETWORKS] folder.

Settings (Step 2 Network Settings)

2-2 Setting PC's IP Address [Windows XP]

Upon installing the camera, set the IP address of the PC that is used to operate this camera.

For Windows XP, set according to the following procedure.

(For Windows 2000,  Page 30)

Note

Under a DHCP environment and when the IP address assigned to V. Networks is already known, it will not be necessary to perform 2-2 "Setting PC's IP Address" as the PC's IP address is automatically acquired from the DHCP server.

1. Click .

- Right-click on [My Network] and select [Properties].

2. Select the network for which the PC that operates this camera is connected to.

- Right-click to select [Properties].

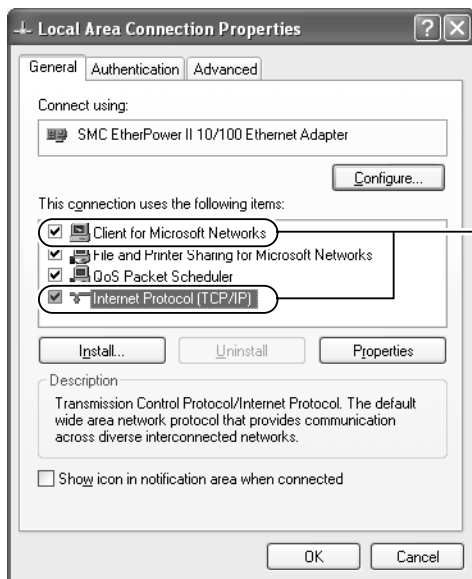

- Ensure that it is selected.

Note

Select "Install (N) ..." if [Client for Microsoft Networks] or [Internet Protocol (TCP/IP)] is not displayed.

3. Select [Internet Protocol (TCP/IP)] and click [Properties].

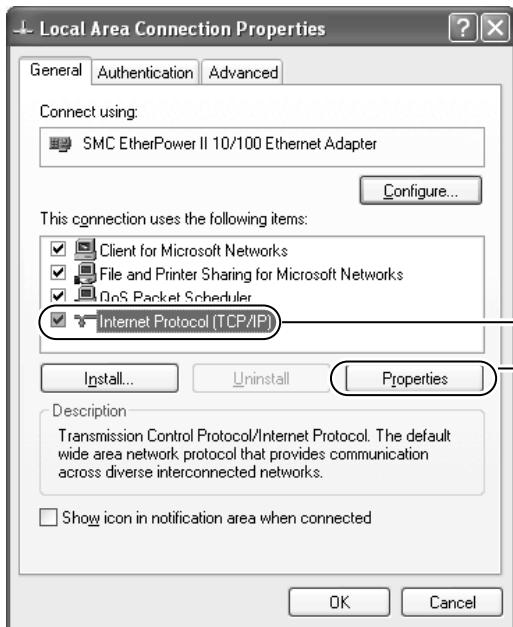

① Select [Internet Protocol (TCP/IP)].

② Click [Properties].

4. Select [Use the following IP address], set the [IP address] and [Subnet mask] and click [OK].

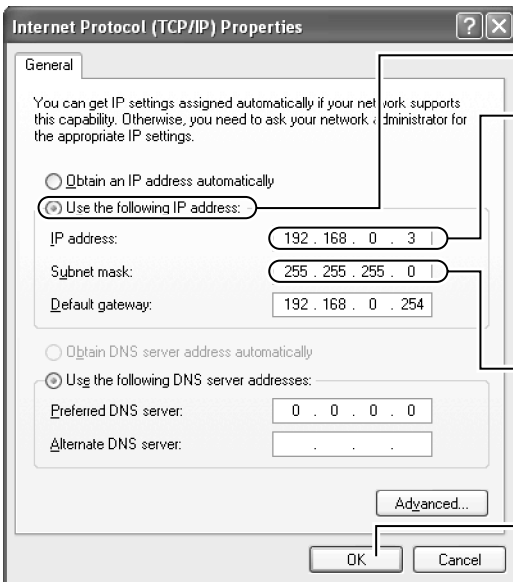

① Select [Use the following IP address].

② Set [IP address] to 192.168.0.3.

Notes

- Make sure to note down the original IP address before changing.
- Do not use the same IP address elsewhere within the same network environment.

③ Set Subnet mask to an appropriate value. Ask the network administrator if necessary.

④ Click [OK].

5. Click [OK] on the [Local Area Connection Properties] screen.

Settings (Step 2 Network Settings)

2-2 Setting PC's IP Address [Windows 2000]

Upon installing the camera, set the IP address of the PC that is used to operate this camera. For Windows 2000, set according to the following procedure.

1. Click [Start].

- Select [Settings] and click [Properties].

2. Double-click [Network and Dial-up Connection].

3. Double-click [Local Area Connection].

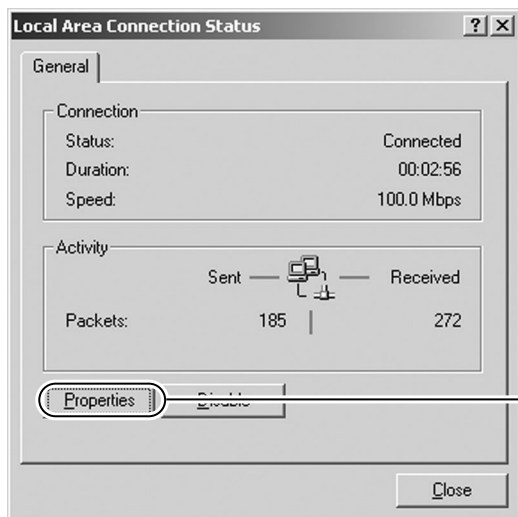

① Click [Properties].

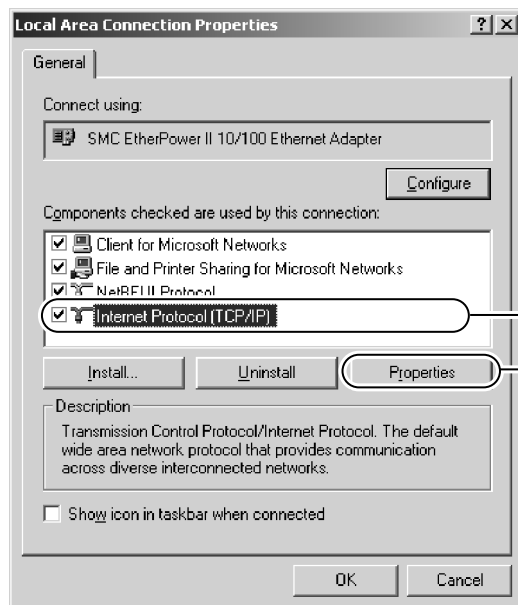

② Select [Internet Protocol (TCP/IP)].

③ Click [Properties].

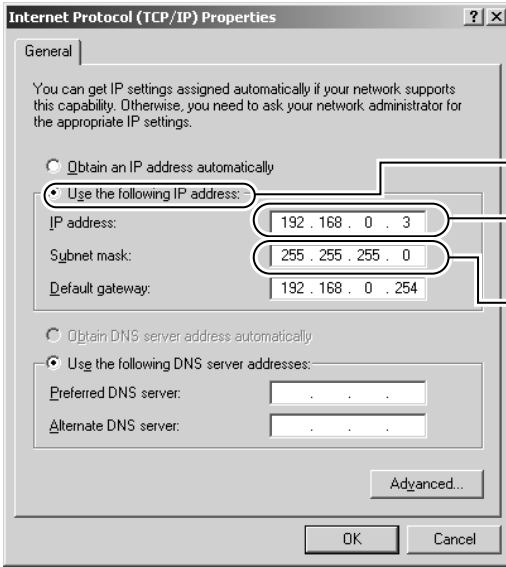

④ Select [Use the following IP address].

⑤ Set [IP address] to 192.168.0.3.

⑥ Set Subnet mask to an appropriate value. Ask the network administrator if necessary.

4. Click .

Settings (Step 2 Network Settings)

2-3 Setting IP Address for this Camera Using the "VN-C205U Setup Tool"

Set the IP address for VN-C205 using the "VN-C205U Setup Tool" that has been installed.
(This "VN-C205U Setup Tool" only allows connection of VN-C205.)

Cautions

- Upon turning on the power of this camera, it may take about 60 seconds before it can be connected to the PC.
- At the factory, DHCP is enabled for VN-C205.
- Using DHCP

JVC does not recommend operating VN-C205 with the DHCP function enabled because a different IP address may be assigned upon the renewal of the leasing contract. The DHCP function of VN-C205 is included with the aim to simplify installation/setting procedures.

Note

To connect to a VN-C205 for which DHCP has been enabled, the DHCP server must exist in an environment where the assigned IP address and MAC address are clearly defined. If the DHCP server is not found, it will automatically start up using the static IP address after 60 seconds.

1. Select [Start] → [Programs] → [V.NETWORKS] →  [VN-C205U Setup Tool] to start up the "VN-C205U Setup Tool".

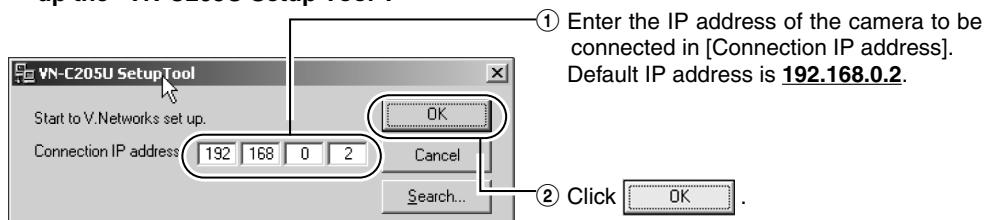

Notes

To view the IP address of the connected camera, click "Search".

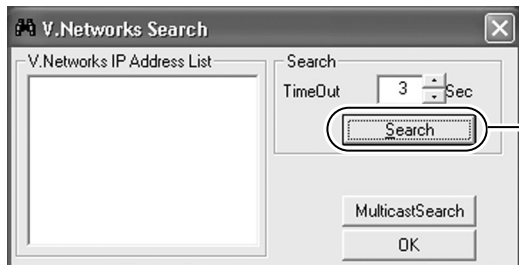

The [V.Networks Search] screen is displayed.

Click  to start search and a [V.Networks IP Address List] will appear.

- [TimeOut] is for setting the time for searching (1 to 30 seconds). If no IP address is displayed upon searching, change the value to a longer time and search again.
- If the [V.Networks] on the LAN has a different subnet from that of the PC, connection may not be possible even if the IP address of the camera is found via search. Change the IP address of the PC to an appropriate value and connect the camera.

2. Check settings.

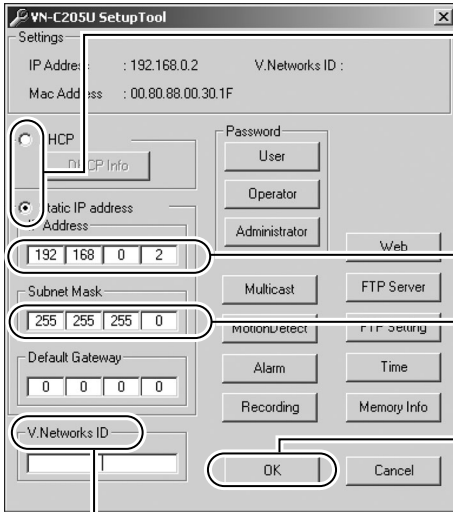

① Select whether to use DHCP.

Note

The IP address of the DHCP server and other information can be checked when [DHCP] is selected.

② Change the IP address to the one assigned to or approved by the administrator.

③ Set Subnet mask to an appropriate value. Ask the network administrator if necessary.

④ Click .

[V.Networks ID] works as an identification code set to VN-C205. Only alphanumeric characters can be used. This ID does not directly affect operation by the user. Normally, the ID is set as CAM00001, CAM00002, etc. (0 to 8 characters)

For other settings,  next page

3. Click .



Click .

Note

Upon clicking OK, VN-C205 will be automatically reset and the set values will be enabled.

4. Start up the "V.Networks Controller".

 Page 34)

Note

In a system where more than 1 VN-C205 is used, turn on the power for a VN-C205 first, followed by setting the camera until "2-3 Setting IP Address for this Camera Using the 'VN-C205U Setup Tool' " is completed. Upon doing so, turn on a second camera and perform setting in the same way. Perform the same procedure for subsequent cameras.

Settings (Step 3 Setting Using the V.Networks Controller)

3-1 Starting Up V.Networks Controller

The installed "V.Networks Controller" can be used to monitor camera images. In addition, recording/playback operations and setting of frame rate for camera images are also possible.

1. Select [Start] → [Programs] → [V. NETWORKS] →  [V.Networks Controller] to start up the "V.Networks Controller".



- ① Select the camera to connect to from the pull-down menu for the camera.



- ② Live images from the camera will be displayed.

Notes

- Enter the correct password if a password has been set.
- This controller can be connected to VN-C1, VN-C2, VN-C3, VN-C30 (JPEG only), VN-A1, VN-C10 (JPEG and MPEG), VN-C655 and VN-C625 as well VN-C205.

3-2 Features that Allow Setting Using the V.Networks Controller

The V.Networks Controller can be used to perform settings for image size and alarm.

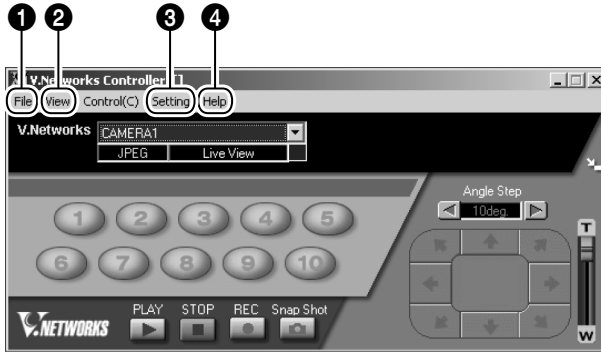

① File

New : Creates a new file if the camera is connected for the first time.

Delete : Deletes a file.

Motion Detection Standby

: Select the camera for which the Motion Detection Standby function is to be enabled.

Exit : Exits the controller.

② View

Image Size : Sets the image display size.
JPEG : 640 x 480
320 x 240

Upside Down: Displays the image inversely.

Note

The video output is not inverted.

③ Setting

Quality : For setting the compression rate.

Frame rate : For setting the number of camera images to send per second.

Alarm Reg : Alarm operation will be enabled if this item is checked.

Alarm Setting : For setting alarm actions for each alarm.

Time Stamp : For setting the date and time display of a stored file.

Property : For changing information of cameras that are not currently connected.

④ Help

About : For checking the version of the V.Networks Controller.

* As for the details of other settings and “Step 4 Operation Using the V.NETWORKS Controller”, read “Instruction Manual” (PDF) in the supplied CD-ROM.

Operations (Step 5 Operating Using a Web Browser)

In addition to the controller software supplied, web browsers can also be used to view still/motion images as well as to perform various settings.

5-1 Operating Environment

The following environment will be required to view/operate VN-C205 using a web browser.

The PC in use shall also meet requirements on the operation environment stated in this manual (☞ Page 8).

PCs installed with the following web browsers

- Internet Explorer 5.x or 6.x.
- For CPU performance, required memory space and other values, please refer to the recommended values by the respective web browser in use.

In order to enable smooth display of motion images on a large screen, it will be necessary to ensure adequate allowance as compared with the recommended values by web browsers. In addition, images of the installed camera cannot be properly displayed using 256 color modes.

Caution

Operation using the web browser requires an environment that enables proper running of Java. Please refer to our web site for details.

<http://www.jvc-victor.co.jp/english/pro/vnetworks/index-e.html>

LAN Environment

- VN-C205 functions as a web server that makes use of a HTTP protocol.
Access linking by host name will be possible as long as the environment allows use of a DNS (Domain Name System).
- It is possible to establish a 1-to-1 connection between the PC and VN-C205 using a crossover cable. (Although rare, the use of crossover cables may not be possible with some LAN boards. Be sure to check before using.)

Notes

Web Page Images

Web page screens in this manual are web page data inside VN-C205 (including images shot using the installed camera) which are displayed using the web page browsing/display function of the browser.

As such, the format of web pages and fonts displayed may vary according to the type of browser and settings.

In the event that items on the screen are not fully displayed, hence causing problems during use, display all items such as by resizing the window.

Description in this manual is based on the web page browsing/display screen of Internet Explorer.

Password

Upon changing a password, the password confirmation screen may appear, which requires you to enter the new password twice. When this screen appears, enter the same password twice.

5-2 Access Authorization Level

The configuration of URLs (web pages) in VN-C205 is illustrated as follows.

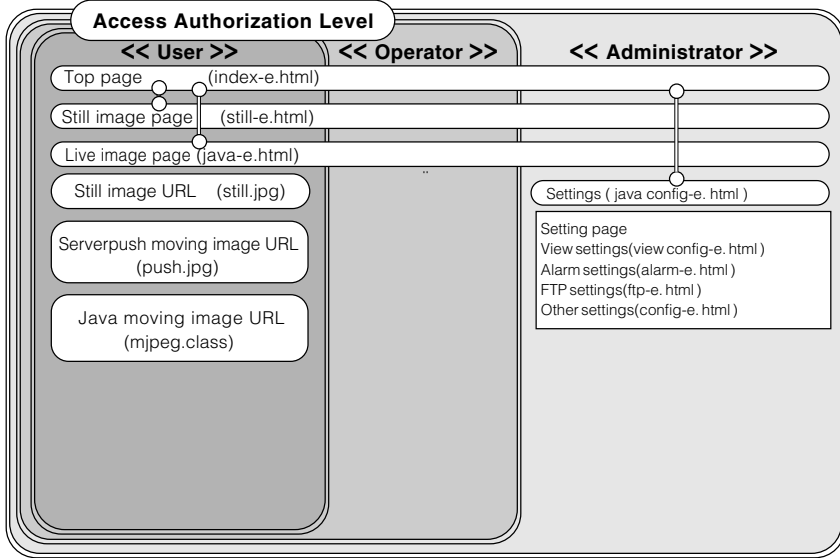

Front Page: http://*****/index-e.html ("*****" represents the URL of VN-C205)
This page provides links to the various web pages of VN-C205.

Authentication of Access Authorization

When there are authenticated passwords, a message requesting entry of user name and password (access authorization authentication) will appear.

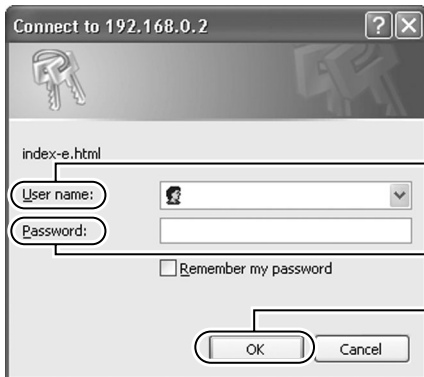

① User name is not used.

② Enter a password among the 3 different levels that have been set.

③ Click .

Note

It is recommended that you register a URL (Uniform Resource Locator).

To speed up display of VN-C205 web pages using your web browser, register the URL information during the access test using the set IP address or DNS host name.

This is represented by [Favorites] in Internet Explorer. To register, use the [Add to Favorites] item in the operation menu of the web browser when a VN-C205 web page is displayed.

Operations (Step 5 Operating Using a Web Browser)

5-3 Starting Up the Web Browser

Specify the default web page address of VN-C205 as the page to view using the web browser. (Upon entering the factory setting of the IP address, the web browser will display the front page of VN-C205.)

Note

You may not be able to specify the IP address directly if a proxy server is set for accessing the Internet. In this case, change the proxy settings to enable direct specification.

1. Start up the web browser.

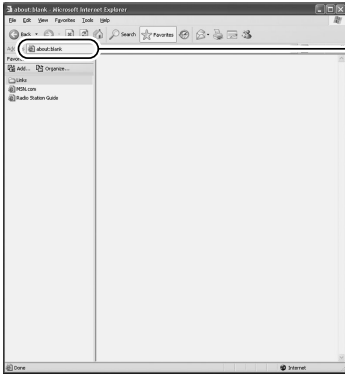

"http://192.168.0.2/index-e.html"

Note

The terms "Top Page" and "Home Page" are defined as follows in this manual.

Top Page : Refers to /index-e.html

Home Page : • Refers to the specified html page when the default page feature is enabled.
• /index-e.html will be used when the default page is disabled.

2. The Top page will be displayed.



Still Image of VN-C205
Camera image at the point when browsing starts is displayed.

Link buttons to various web pages.
(Click once to jump to these pages.)

- Still Image
- Live Image
- Settings

* For details, refer to the PDF instruction manual inside the supplied CD-ROM.

Others

Specifications

■ Camera

Image pickup device : 1/4-inch type, interline transfer CCD,
768 (H) x 494 (V)

Sync system : Internal

Scanning frequencies : 15.734 kHz (Horizontal),
59.95 Hz (Vertical)

White Balance : ATW/Manual (Switchable)

ATW : Color temperature range
2,300 K to 10000 K

Backlight compensation : ON/OFF (Switchable)

Easy Day & Night: ON/OFF (Switchable)

[Video Output]

Color System : NTSC

S/N : 48 dB
(AGC: OFF, Typ.)

Horizontal resolution : 540 TV lines (Typ.)

Minimum object illumination : **(Color mode):**
3.0 lx (50% output, AGC ON, Wide-end)
1.5 lx (25% output, AGC ON, Wide-end)
(Black & White mode):
2.0 lx (50% output, AGC ON, Wide-end)
0.9 lx (25% output, AGC ON, Wide-end)

■ Lens

Focal length : 2.6 mm to 6 mm (variable)

Maximum aperture : F1.2 (Wide) to F1.8 (Tele)

Angle of vision : f = 2.6 mm
82° (H) x 59° (V)
f = 6 mm
35° (H) x 26° (V)

Angle adjustment range : Horizontal : 120°
Vertical : +80°, -50°
Tilt : ±15°

■ **LAN Standard** : IEEE802.3, IEEE802.3u

■ Communication

protocol : TCP, UDP, FTP, ICMP, ARP,
DHCP, NTP, HTTP

■ General

Power supply : AC 24 V ~ 50 Hz/60 Hz
DC 12 V =

Power consumption : 0.8 A

Ambient

temperature : 0°C to 40°C

Humidity : 20% to 85% RH (without condensation)

Mass : Approx. 1.0 kg

Accessories : Read Me First 1
CD-ROM 1
Warranty Card 1
Service Information Card 1
Template 1

■ External Dimensions [Unit: mm (inches)]

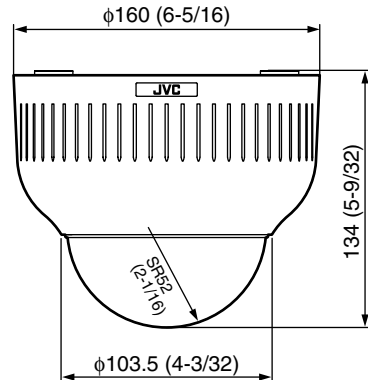

* **Specifications and appearance of this unit and related products are subject to change for product improvement without prior notice.**

VN-C205 FIXED DOME NETWORK CAMERA

JVC